

**LEARNING MATERIAL OF
POWER STATION ENGINEERING
PREPARED BY – ER. DEWAN KUMAR SAHU
&
ER. SAMIR SAHU**

CHAPTER – 1

Q1. Define geo-thermal energy ? 2012 (s) 1(a), 2015(s)

Ans: Geothermal energy is the energy which lies embedded within earth.

There are at least seven types of geothermal resources.

- (a) Dry steam fields
- (b) Wet Steam fields
- (c) Hot water
- (d) Geo pressure field
- (e) Magma deposit
- (f) Hot dry rock
- (g) Volcanoes.

02. Application of wind mill ? 2012 (s) 1(c)

Ans:(a) To store the electric power generated by windmills in rechargeable batteries.

(b) Storing in the form of potential energy by pumping & storing water in high level reservoirs

(c) Storage in flywheel in the form of mechanical energy.

03. What is captive power station. 2012 (w)1(a), 2012 (s) 1(b) 2016 1.(a)

Ans: Captive power station or Industrial power station is run by a manufacturing company for its own use & its output is not available for general sale.

Normally these plants are non-condensing because a large quantity of steam is required for different manufacturing operation.

Q what is terrestrial heat 2017(s)

It is the most direct observation of the thermal state of the earth, and geothermal processes play an important role in all theories of Earth's origin, constitution, and behavior.

By **definition**, the surface (**terrestrial**) **heat** flow at a given locality is the rate of **heat**.

DEFINE POWER PLANT AND NAMES ANY TWO TYPES 2019

A **power station** (also referred to as a generating **station**, **power plant**, powerhouse or generating **plant**) is an industrial facility for the **generation** of electric **power**. **TYPES**

OF POWER PLANTS 1.BASED ON INPUT ENERGY /FUEL (a.)COAL thermal Power Plants (b.) HYDRAULIC Power Plants (c.) NUCLEAR Power Plants (d.) GEOTHERMAL

CHAPTER:-2

04. What is Reheat Cycle ? 2012(s) 1(d)

Ans: In order to increase the life of turbine blades it is necessary to keep the steam dry during its expansion. It is done by allowing the steam to expand to an intermediate pressure in a high pressure turbine & then taking it out & sending back to the boiler where it is reheated at pressure until it reaches the inlet temperature of the first stage. This process is called reheating.

05. Use of feed water heater ?(2015-s)

- Ans:**
- a) The function of feed water heater is to raise the temperature of feed water by means of bled steam before the feed water is supplied to the boiler.
 - b) The heat being taken from the exhaust steam of steam engine cylinder or steam turbines.

Four boiler accessories of the boiler 2019

1 feed pump

2 economiser

3 air pre heater

4 super heater

06. What is regenerative cycle ? 2013 (w) 2017 (S)

Ans: The methods which adopted to heat the feed water from the hot well of condenser irreversibly by inter-change of heat within the system and thus improving the cycle efficiency. This heating method is called regenerative feed heat & the cycle is called regenerative cycle.

Advantages and limitation of steam power plant 2019

:

Advantages

- As compared with power generating plant, it has low initial cost and hence economical.
- Less land area is required as compared with the hydro power plant.
- Coal is used as fuel and the cost of coal is cheaper than petrol and diesel fuel. So the power generation cost is economical.
- This power plant has easy maintenance cost.
- Steam power plant can be installed in any area where water sources and transportation facility are easily available.

limitation

- The running cost of steam power plant is comparatively high because of fuel, maintenance etc
- If we talk about the overall efficiency of steam power plant, than is about 35 % to 41% which is low.
- Due to the release of burnt gases of the coal or fuel, it contributes to the global warming to a larger extent.
- The heated water that is thrown in the rivers, ponds etc puts and adverse effect on the living organism of water and disturbs the ecology.
- living organism of water and disturbs the ecology.

gas reheating and live steam reheating cycle 2019

Reheating is applied in a gas turbine in such a way that it increases the turbine work without increasing the compressor work or melting the turbine materials. When a gas turbine plant has a high pressure and low pressure turbine a reheater can be applied successfully. Reheating can improve the efficiency up to 3 % .

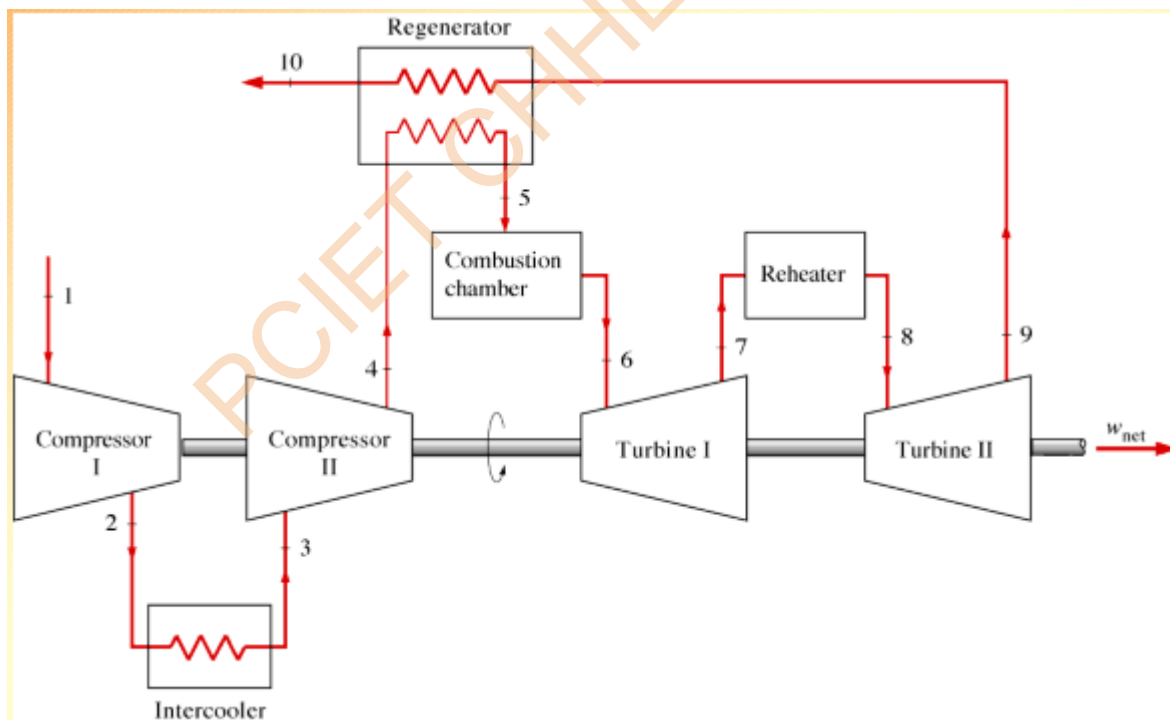

being at very low pressure the exhaust coming out of the turbine and entering the condenser carries some of kinetic energy and useful enthalpy, which is direct energy loss.

Radiation and convection losses

The steam turbine **Write the types of losses in steam turbine and explain**
2019

Any **turbomachine** extracts energy from high-pressure **steam** and converts it into shaft work. The total energy content available in steam supplied to the **steam turbine** is not completely recovered in the form of **mechanical energy**. There are certain losses in energy of steam which occur inside a turbine...

Admission losses[

In practice the flow of steam through **nozzle** is not **isentropic**, but accompanied with losses which decrease the kinetic energy of steam coming out of the nozzle.

The decrease in kinetic energy is due to the following reasons

- **Viscous forces** between steam particles
- Heat loss from steam before entering the nozzle
- Deflection of flow in the nozzle
- Boundary layer development in the nozzle
- **Turbulence** in the nozzle
- The friction in the nozzle which reduces available **enthalpy** drop and hence actual velocity leaving the nozzle is less than that obtained with is-entropic expansion

Leakage losses[

Steam leaves the **boiler** and reaches the **condenser** after passing through the main valve, regulating valves, nozzles, clearance spaces between nozzles and moving blades, diaphragm and rotating shaft etc. Further there is large pressure difference between inside of steam turbine and the ambient and also from one location to another location across these devices.

Therefore, steam leakage takes place through

- Main valve and regulating valve
- Seals and glands
- Spaces between nozzles and moving blades
- Spaces between diaphragm and shaft of turbine
- Space between moving blade rings and turbine casing
- leakage of steam through these is a direct loss of energy.

Friction losses

Frictional resistance is offered during flow of steam through nozzles on moving and stationary blades. In most of the turbines the blade wheels rotate in a space full of steam. The viscous friction at the wheel surface causes admission losses as steam passes from nozzle to wheel. The effect of partial admission creates eddies in the blade channels.

The surface of curved moving blades and stationary blades offers resistance, which increases with increase in roughness of blade surface and relative velocity between steam and rotating blade.

The energy loss also takes place when the steam jets turns along the curvature of the blade surface. The turning losses depend on the angle of turning.

Exhaust loss

The energy content of steam is not fully utilized in the turbine. Despite of operates at a relatively high temperature; therefore some of the heat energy of steam is radiated and convected from the body of the turbine to its surrounding. These direct losses are minimized by proper insulation.

Losses due to moisture

The steam passing through the last stage of turbine has high velocity and large moisture content. The liquid particles have lesser velocity than that of vapor particles and hence the liquid particles obstruct the flow of vapor particles in the last stage of turbine and therefore, a part of kinetic energy of steam is lost. If the dryness fraction of steam falls below 0.88, the erosion and corrosion of blades can also take place.

Flow diagram of rankine cycle 2019



2019

BLOCK DIAGRAM OF RANKINE CYCLE

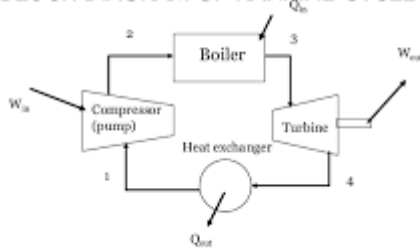

Q. Elements of Steam Power Plant. 2011(s)

Ans: The different types elements of steam power plants are:

- | | |
|----------------------------|----------------------------|
| (a) Boiler | (b) Steam turbine |
| (c) Generator | (d) Condenser |
| (e) Cooling Tower | (f) Circulating water pump |
| (g) Boiler Feed pump | (h) Wagon tippler |
| (i) Crusher house | (j) Coal mill |
| (k) Induced draught fan | (l) Ash Precipitators |
| (m) Boiler chimney | (n) Forced draught fan |
| (o) Water treatment plants | (p) Control room |
| (q) Switch yard | |

Boiler:-

- **Boiler or steam generators convert water into steam with the help of heat produced by the burning of coal.**
- **It is one of the major equipments in a steam power plant.**
- **Boiler used in steam power plant of two types namely. Water tube boiler, fire tube boiler.**
- **In fire tube boiler two tubes containing hot gases of combustion in side are surrounded with water which is water tubes boiler the water is inside the tubes and hot gases out side the tubes.**
- **A modern boiler may be producing steam at the rate of 375 tones per hour at 14 MPa 540°C and burning coal at the rate of 200 tones/hours.**
- **The temp. Inside the furnace where fuel is brunt is of the order of 1500°C.**
- **The boiler furnace is a chamber in which fuel is brunt to liberate heat energy.**
- **The boiler furnace walls are made up off refractory material such as fire day, cylinder etc.**
- **The inside of boiler also contains separates set of tubes which constitute heat exchanges in which heat in the flue gases is exchanged with other medium.**
- **There (a) super heater (b) RE-heater (c) Economizer (d) Air Pre heater**

Super heater :

- **The super heater is situated at the hottest part of the boiler**
- **It is meant to rise the steam temp. above the saturation temp. by absorbing beat from the flue gases.**
- **The present trend is to keep the steam temp. at 540°C.**
- **The superheating of steam makes it possible to recover more energy from steam which improves the cycle efficiency.**
- **From the super heater the steam is led to high pressure turbine.**

Re- heater

- **The function of the re-heater is to re superheat the party expanded steam from the turbine.**

- **this is done so that the steam remains dry as far as possible through the last stage of the turbine.**
- **Modern plants have re heaters as well as super heater in the same gas passes of the boiler**

Economizer:-

- **The function of an economizer in a boiler is to absorb heat from the out going the gases to rise the temp. of the feed water coming from the condenser.**
- **It raises boiler efficiency causes saving in the fuel consumption.**
- **It involves extra cost of installation, maintenance and regular cleaning.**

Air pre heater:-

- **It is used to recover heat from the exhaust flue gases.**
- **It is installed between the economizer and the chimney.**
- **It increases the efficiency of the boiler.**

Steam Turbine:-

- **It convert the heat energy in the steam into rotational mechanical energy.**
- **It gives high speed (3000 × 1500) rpm maximum size (1000 mm) minimum floor space, suitability for highest steam pressure and stem temperature.**

Generator:-

- **It is directly coupled to the turbine shaft converts mechanical energy of turbine shaft into the electrical energy.**
- **It consists of two electrical windings, one is mounted as the turbine shaft rotating with its and is called rotor.**
- **The other is arranged as a should around the rotor fixed to the Flore and is called starter.**
- **The relative motion of rotor and starter generates the electricity**

Condenser :-

- **Then function of the condenser is to condense the steam which has been discharged from low pressure turbine.**

- The condenser is a large panel containing a large no. of brass tubes through which the cold water is circulated continuously for condensing steam flowing the outside the surface of the tubes.
- The hot condensate flows back to the boiler to be reconverts into steam.

Cooling Tower:-

- The function of cooling tower is to cool the hot cooling water coming out of the condenser in closed circulation cooling water system.
- Here the hot water is cooled in constant with the atmospheric air
- the hot cooling water gets collected in the cooling tower basin and is pumped back through the condenser.
- It may cool 18,000 tones of water per hour by 0°C.

Circulating water pump:-

- A circulating water pump circulates cooling water in a closed system comprising of turbine condenser and cooling tower.

Boiler feed pump:-

- A boiler feed pump is like a heater to the steam power plant
- The main aim of the boiler feed pump is to rise the pressure which is coming from the condenser to the boiler
- A feed pump may be centrifugal or reciprocating type.
- A double acting reciprocating pump is commonly used as a feed water in there days, the duplex feed pump is commonly used

Wagon tippler:-

- The coal may be transported to the plant site by rail wagon.
- The coal is unloaded at the plant side mechanically by means of wagon tippler
- The loaded wagon is lifted by tipping it in the underground coal hopper from where the coal is carried by belt conveyer to the crusher house.

Crusher house:-

- Coal unloaded by wagon tippler is carried to crusher house through conveyer for crushing
- Here the coal is crushed to a size of 10 mm
- The crushed coal is then supplied to boiler now coal bunkers.

Coal mill :-

- The function of coal mill is to pulverize the raw coal into a fine powder before it is burnt in the boiler furnace.

Induced draught fan :-

- The fan is placed after the fire grate. The pressure inside the boiler is below than the atmospheric pressure. It sucks the hot gases from the combustion chamber and forces them in to a chimney.

Ash precipitators:-

- To avoid air pollution the outgoing flue gases should be treated from dust particles before these escape into the atmosphere through the chimney. This done with the help of two precipitators. Mechanical & electrical precipitators.
- In mechanical precipitators the conveyer's ash particles are separated by centrifugal action.
- In electrostatic precipitators which removes fine ash particles the flue gases made to pass through high voltage electric field. The ash particles get joined and are attached towards the cooling electrodes.

Boiler Chimney:-

- The flue gases from the boiler after removal of the fly ash in the precipitators are help off to the atmosphere through boiler chimney.
- A protective coating of acid resistance paint is applied outside in its top 10 mts.

Forced draught fan :-

- the fan is placed before the fire grate. The pressure inside the furnace is above than atmospheric pressure. It force fresh air into the chamber.

Water treatment plant:-

→ To avoid any scale formation in boiler tubes the feed water to be used in boiler has to be chemically treated in water treatment plant.

Switch Yard :-

→ The switch yard houses transformers, circuit breakers and switches for connecting and disconnecting the transformers and circuit breakers.

Control room:-

→ The control room is the operational nerve centers of a power station. The performance of all plants equipment is constantly monitored here with the help of sophisticated instrumentation and controllers. The control room is air conditioned to maintain the desired temp. for proper functioning of the instruments. Any abnormal deviation in the parameters of the various system is immediately indicated by visual and audio warning and suitable corrective action is taken.

Compare between Regenerative and recuperative air preheater 2019

There are **two** broad classes of **air preheater**, the regenerative heaters and the recuperative heaters.

- The **recuperative** heater is a plate-type or tubular heat exchanger operating as either a countercurrent or crossflow unit. A soot-cleaning system, rather than a soot-blower system, is commonly used to clean the flue-gas side of these heat exchangers.

- The **regenerative** air preheater, or Ljungstrum heater, employs a large rotor assembly with approximately half of the element mounted in the exhaust gas duct and the other half in the supply air duct. The rotating element, which usually turns 2 to 4 r/min, contains many corrugated laminae that are alternately heated by the flue gas and cooled by the combustion air.

The air preheaters are useful in other ways than just improving the overall efficiency of the unit, it reduces the time required for fuel ignition, thereby improving fuel combustion.⁴⁷

In a regenerator heat from the primary medium is first stored in a thermal mass and later (next cycle) regenerated from that mass by the secondary medium. The thermal mass can be the wall material of the flow ducts or a porous medium, through which alternating the primary and the secondary flow is led.

In a recuperator both media are separated by a wall through which heat is transferred directly.

Q. Explain Rankine Cycle P.V.R. temperature Entropy diagram Derive efficiency
2016 2(b)2019

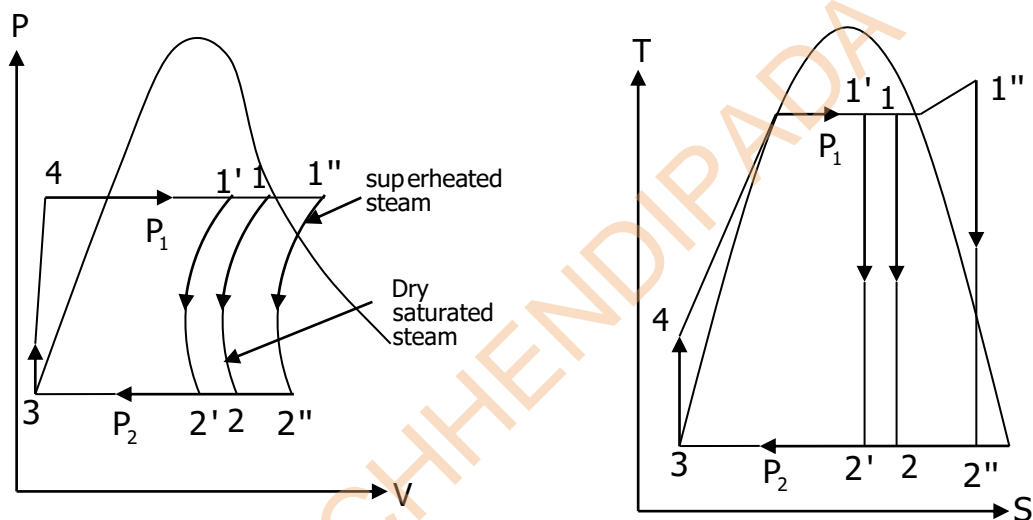

Ans: Consider 1 kg of fluid in the cycle & applying steady flow energy equation to each component in the cycle.

1. For Boiler

$$hf_4 + Q_1 = h_1$$

$$\Rightarrow Q_1 = h_1 - hf_4$$

2. For turbine

$$H_1 = W_T + h_2$$

$$\Rightarrow W_T = h_1 - h_2$$

3. For condenser, $h_2 = Q_2 + hf_3$

$$\Rightarrow Q_2 = h_2 - hf_3$$

4. For pump, $hf_3 + wp = hf_4$

$$\Rightarrow wp = hf_4 - hf_3$$

$$\therefore \eta_{Rankine} = \frac{W_{net}}{Q_1} = \frac{W_T - W_p}{Q_1} = \frac{(h_1 - h_2) - (hf_4 - hf_3)}{h_1 - hf_4}$$

For reversible adiabatic compression we get

$$Tds = dh - Vdp$$

$$dh = vdp \quad (\because ds=0)$$

$$\Rightarrow dh = hf_4 - hf_3 = v_3 \int P_1 - P_2$$

Where p is in bar and v is in m^3/kg

$$Hf_4 - hf_3 = v_3 (P_1 - P_2) \times 10^5 \text{ J/kg}$$

The feed pump ($hf_4 - hf_3$) being a small quantity in comparison with turbine work is neglected when boiler pressure are low.

$$\eta_{\text{Rankin}} = \frac{h_1 - h_2}{h_1 - hf_4}$$

Q. Lay out of steam power plant ? 2010 , 1(c)

A:

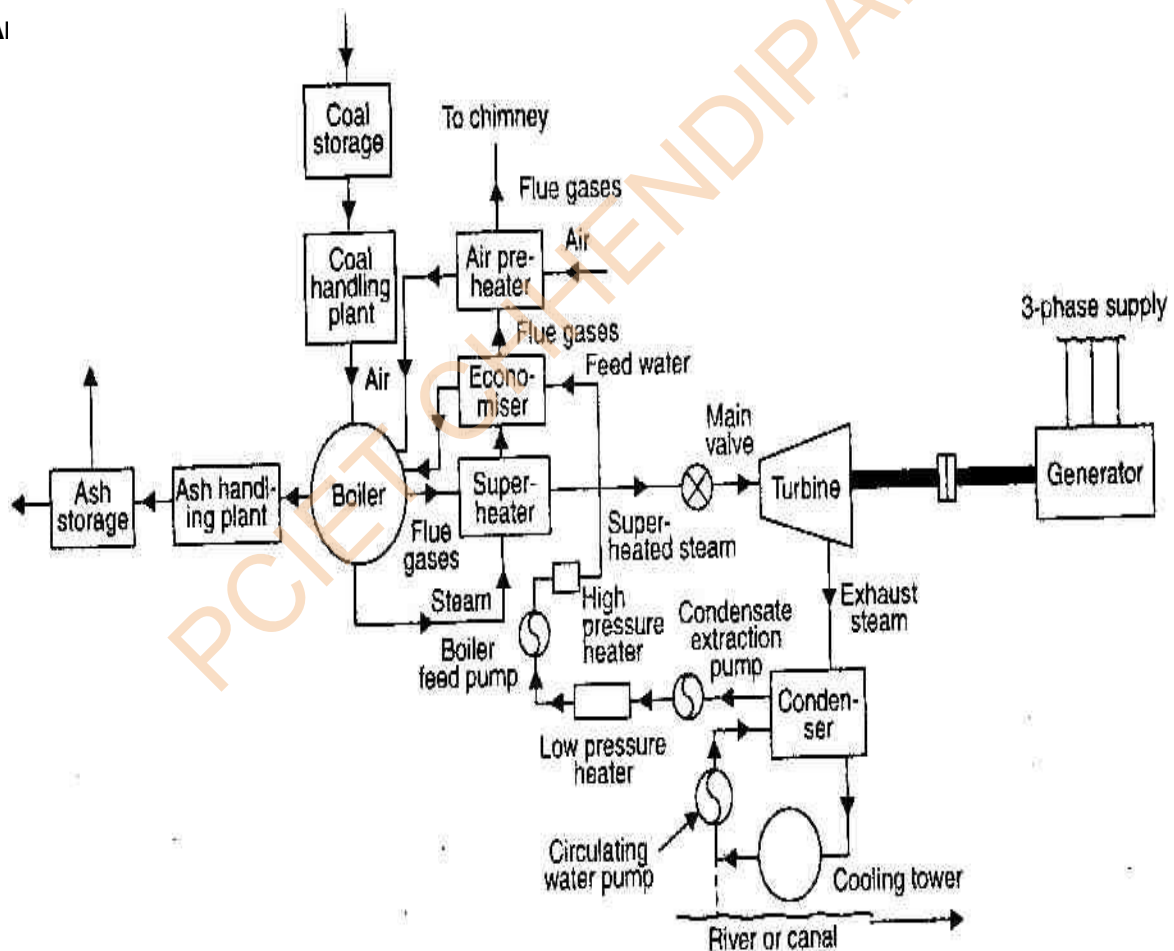

The layout of steam power plant comprises of following four circuits.

1. Fuel & ash circuit.
 2. **Air and Gas circuit**
 3. **Feed water and Steam circuit**
 4. **Cooling water circuit.**
1. **Fuel and Ash circuit:-**

In case of small power plant the quantity of coal being small. Manual unloading from rail car may be used but for large power station the unloading from railway siding is done with the help of wagon tripper and then the coal is conveyed to the coal handling plant. Then it is passes on to the furnaces through the fuel. Feeding devices. Ash resulting from the combustion of coal collects at the back of the boiler and is removed to ash storage yard through ash handling equipment.

2. **Air & Gas Circuit:-**

Air is taken in from atmosphere through the action of a forced or induced draught fan and passes on to the furnaces through the air-pre heater. The flue gases after passing around boiler tubes and super heater tubes in the furnace pass through a dust catching device or precipitator, then through the economizer and finally through the air pre-heater before being exhausted to the atmosphere.

3. **Feed water and steam flow circuit:-**

The steam coming out of the turbine is condensed and the condensate is extracted from the condenser by the condensate extraction pump & is forced to the low pressure feed water heater where its temperature is raised by the heat from bled steam. The feed water is now pumped through deaerator to high pressure feed water heater, where its get heated by the heat from bled steam extracted at suitable point of the steam turbine. A small part of steam (about 1 %) of steam and water is passing through the different component of the system is lost. In boiler water is converted into high pressure steam, which is wet. Wet steam is passed through super heater where it is dried and further

superheated and then supplied to the steam turbine through main valve.

4. Cooling water circuit:-

The cooling water supply to the condenser helps in maintaining a low pressure in it. The water may be taken from a natural source such as river, lake or sea or the same water may be cooled and circulated over again. In the later case the cooling arrangement is made through spray pond or cooling tower.

Q. Function of air extraction pump it is located in the centre of the tubes which result in radial flow of the steam 2015(s)

Ans: Nozzle governing

The efficiency of a steam turbine is considerably reduced if throttle governing is carried out at low loads. An alternative and more efficient form of governing is by means of nozzle control. Fig. shows a diagrammatic arrangement of typical nozzle control governing. In this method of governing, the nozzles are grouped together 3 to 5 or more groups and supply of steam to each group is controlled by regulating valves. Under full load conditions the valves remain fully open.

When the load on the turbine becomes more or less than the design value, the supply of steam to a group of nozzles may be varied accordingly so as to restore the original speed.

Nozzle control can only be applied to the first stage of a turbine. It is suitable for simple impulse turbine and larger units which have an impulse stage followed by an impulse reaction turbine. In pressure compounded impulse turbines, there will be some drop in pressure at entry to second stage when some of the first stage nozzles are cut out.

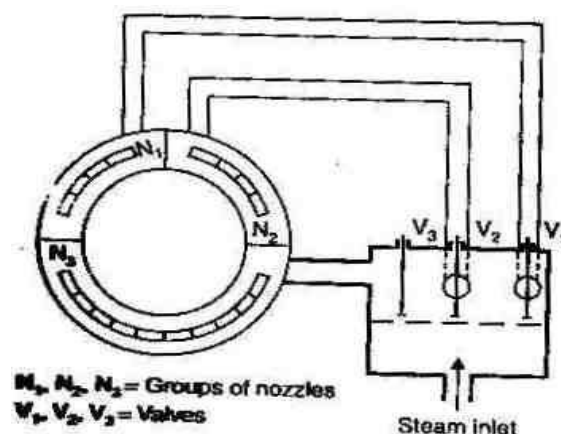

**Q. Explain with neat sketch the working of surface condenser. 2015
3(b)**

Ans: Most condensers are generally classified on the direction of flow of condensate, the arrangement of the tubing and the position of the condensate extraction pump. The following is the main classification of surface condensers:

- i) Down flow type
- ii) Central flow type
- iii) Inverted flow type
- iv) Regenerative type
- v) Evaporative type
- i) **DOWN FLOW TYPE:-**

In fig. is shown a down flow type of surface condenser. It consists of a shell which is generally of cylindrical shape; though other types are also used. It has cover plates at the ends and furnished with number of parallel brass tubes. A baffle plate partitions the water box into two sections. The cooling water enters the shell at the lower half section and after travelling through the upper half section comes out through the outlet. The exhaust steam entering shell from the top flows down over the tubes and gets condensed and is finally removed by an extraction pump. Due to the fact that steam flows in a direction right angle to the direction of flow of water, it is also called cross-surface condenser.

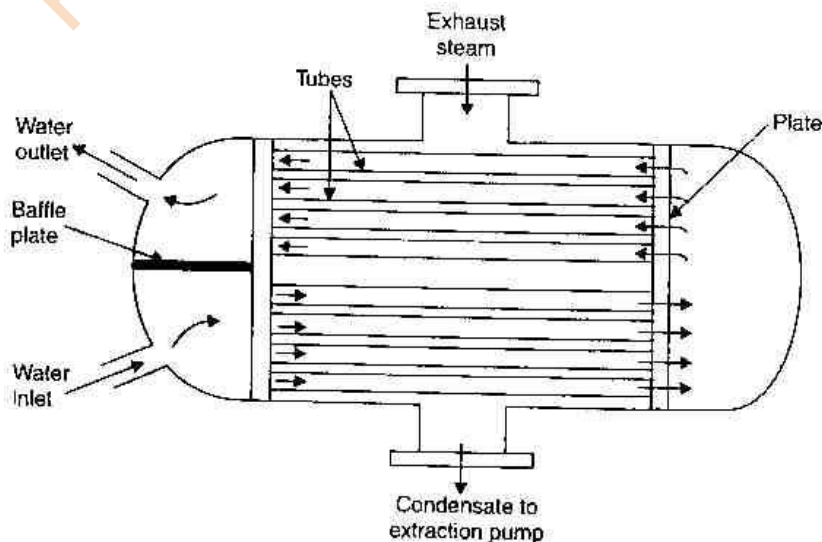

ii) CENTRAL FLOW TYPE

In this type of condenser, the suction pipe of the air extraction pump is located in the centre of the tubes which results in radial flow of the steam. The better contact between the outer surface of the tubes and steam is ensured, due to large passages the pressure drop of steam is reduced.

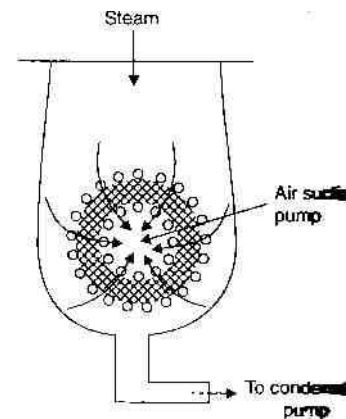

iii) INVERTED FLOW TYPE

This type of condenser has the air suction at the top, the steam after entering at the bottom rises up and then again flows down to the bottom of the condenser, by following a path near the outer surface of the condenser. The condensate extraction pump is at the bottom.

iv) Regenerative type :-

thus rising the temperature of the condensate, for use as feed water for the boiler.

v) Evaporative type

The schematic This type is applied to condensers adopting a regenerative method of heating of the condensate. After leaving the tube nest, the condensate is passed through the entering exhaust steam from the steam engine or turbine sketch of an evaporative condenser. The underlying principle of this condenser is that when a limited quantity of water is available, its quantity needed to condense the steam can be reduced by causing the circulating water to evaporate under a small partial pressure.

The exhaust steam enters at the top through gilled pipes. The water pump sprays water on the pipes and descending water condenses the steam. The water which is not evaporated falls into the

open tank (cooking pond) under the condenser from which it can be drawn by circulating water pump and used over again. The evaporative condenser is placed in open air and finds its application in small size plants.

Q. Explain Regenerative Cycle and writes down the advantage & disadvantages of it ?(2012-s)2017-S

Ans: In the Rankine cycle it is observed that the condensate which is fairly at low temperature has an irreversible mixing with hot boiler water and this results in decrease of cycle efficiency, The methods which is adopted to heat the feed water from the hot well of condenser irreversibly by inter-change of heat within the system and thus improving the cycle efficiency. This heating method is called regenerative feed heat and the cycle is called regenerative cycle.

The principal of regeneration can be practically utilized by extracting steam from the turbine at several location and supplying it to the generative heaters. The resulting cycle is known as regenerative or bleeding cycle. The heating arrangement comprises of (i) for medium capacity turbines, nor more than 3 heater (ii) for high pressure high capacity turbine not more than 5-7 heaters 9iii) for turbines of supercritical parameter 8 to 9 heaters.

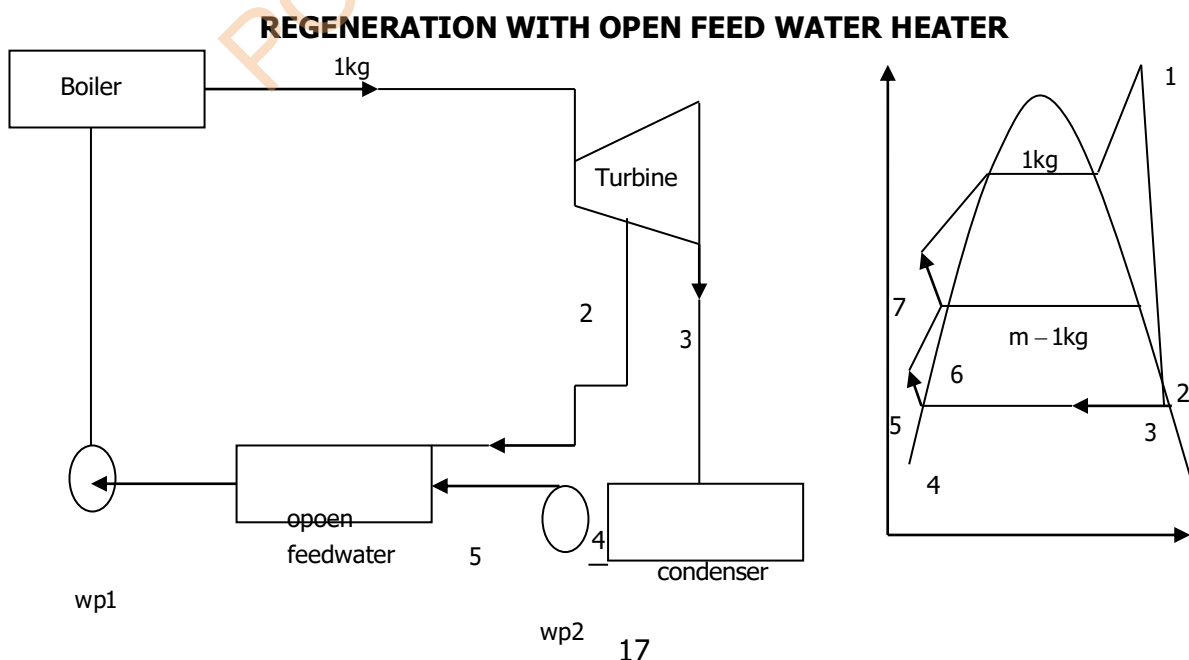

The regenerative cycle with open feed water heater is shown in the fig. a part of superheated steam which enters the turbine at the stable state 1, is extracted from the turbine at the intermediate state 2 of turbine expansions process. The extracted steam is supplied to a heat exchanger known as feed water heater.

The remaining amount of steam on the turbine expands completely to a condenser pressure at state 3. The condensate a saturated liquid at state 4 is pumped isentropically by low pressure pump to the pressure of extracted steam. The compressed liquid at the state 5 enters the feed water heater & it mixes with steam extracted from the turbine. Due to direct mixing process, the feed water heater is called open or direct contact type feed water heater. The portion of steam extracted is so adjusted to make the mixture leaving the feed water to be saturated at the state 6. Now this saturated water is pumped by high pressure pump to the boiler pressure state 7. With this regeneration the average temperature at which heat is supplied has been increased, therefore Rankine Cycle efficiency improves.

Analysis:- Let 1 kg of steam be leaving the boiler entering the turbine. m_1 kg of steam per kg, is extracted at the state 2 from the turbine at the intermediate pressure P_2 ($10m_1$) kg of steam per kg flow through the remaining part of the turbine during expansion from 2- 3 condensation from 3 – 4 & pumping from 4 -5.

$(1 - m_1)$ kg of steam enters in open feed water heater and mixed with m_1 kg of steam blown. From the turbine at the state 2. After mixing the mass of saturated liquid becomes 1 kg at the state 6

and it is pumped to boiler pressure is the state 7. Applying steady flow energy equation to mixing process 2 – 6.

$$(1-m_1) h_5 + m_1 h_2 = h_6$$

$$\Rightarrow h_5 - m_1 h_5 + m_1 h_2 = h_6$$

$$\Rightarrow m_1 (h_2 - h_5) = h_6 - h_5$$

$$\Rightarrow m_1 = (h_6 - h_5) / (h_2 - h_5)$$

The heat supplied in the boiler

$$Q_{in} = h_1 - h_7$$

Heat rejected in the condenser

$$Q_{out} = (1-m_1) (h_3 - h_4)$$

$$W_T = (h_1 - h_2) + (1 - m_1) (h_2 - h_3)$$

$$W_p = (h_7 - h_6) + (1-m_1) (h_5 - h_4)$$

$$\text{Net work done} = w_T = w_p$$

= network done/Heat supplied.

Q-Why compounding of steam turbine is necessary.explain velocity compounding ? (2017 -s)

Compounding of steam turbines is the method in which energy from the steam is extracted in a number of stages rather than a single stage in a turbine. A compounded steam turbine has multiple stages i.e. it has more than one set of nozzles and rotors, in series, keyed to the shaft or fixed to the casing, so that either the steam pressure or the jet velocity is absorbed by the turbine in number of stages.

Types of compounding [\[edit\]](#)

In an Impulse steam turbine compounding can be achieved in the following three ways: -

1. Velocity compounding
2. Pressure compounding
3. Pressure-Velocity Compounding

In a Reaction turbine compounding can be achieved only by Pressure compounding.

Velocity compounding of Impulse Turbine [\[edit\]](#)

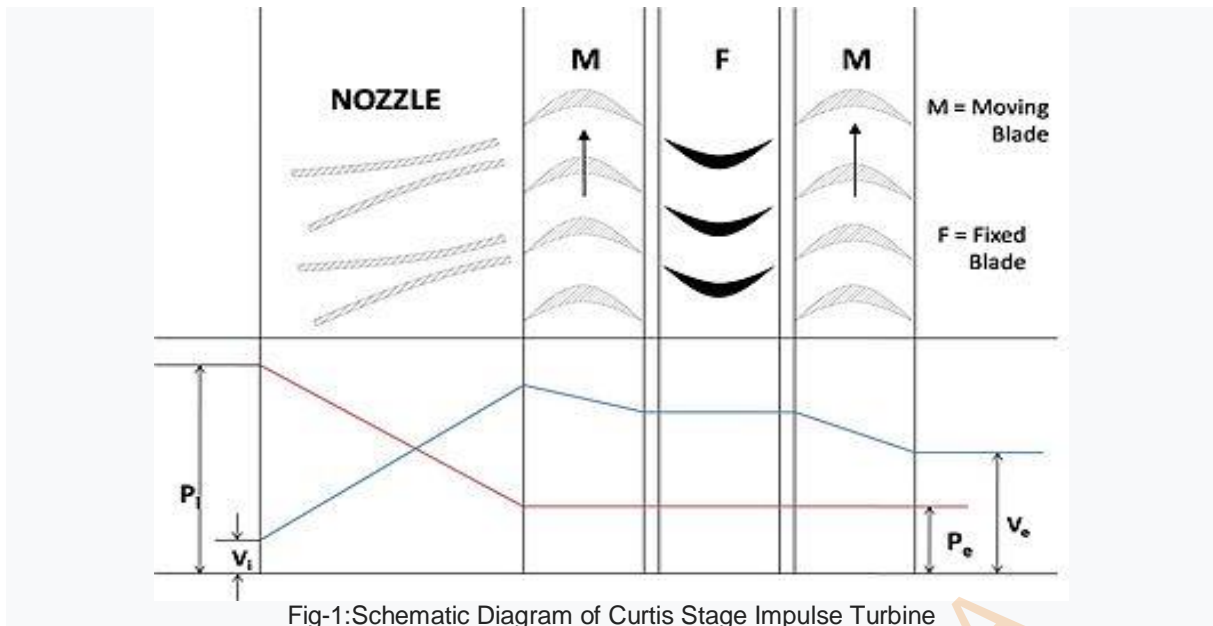

The velocity compounded Impulse turbine was first proposed by C G Curtis to solve the problem of single stage Impulse turbine for use of high pressure and temperature steam.

The rings of moving blades are separated by rings of fixed blades. The moving blades are keyed to the turbine shaft and the fixed blades are fixed to the casing. The high pressure steam coming from the boiler is expanded in the nozzle first. The Nozzle converts the pressure energy of the steam into kinetic energy. It is interesting to note that the total enthalpy drop and hence the pressure drop occurs in the nozzle. Hence, the pressure thereafter remains constant.

This high velocity steam is directed on to the first set (ring) of moving blades. As the steam flows over the blades, due to the shape of the blades, it imparts some of its momentum to the blades and loses some velocity. Only a part of the high kinetic energy is absorbed by these blades. The remainder is exhausted on to the next ring of fixed blade. The function of the fixed blades is to redirect the steam leaving from the first ring of moving blades to the second ring of moving blades. There is no change in the velocity of the steam as it passes through the fixed blades. The steam then enters the next ring of moving blades; this process is repeated until practically all the energy of the steam has been absorbed.

A schematic diagram of the Curtis stage impulse turbine, with two rings of moving blades one ring of fixed blades is shown in **figure 1**. The figure also shows the changes in the pressure and the absolute steam velocity as it passes through the stages.

where,

P_i = pressure of steam at inlet

V_i = velocity of steam at inlet

P_o = pressure of steam at outlet

V_o = velocity of steam at outlet

In the above figure there are two rings of moving blades separated by a single of ring of fixed blades. As discussed earlier the entire pressure drop occurs in the nozzle, and there are no subsequent pressure losses in any of the following stages. Velocity drop occurs in the moving blades and not in fixed blades.

Q – With neat sketch explain governing of steam turbine 2017-s

Steam turbine governing is the procedure of controlling the flow rate of steam to a steam turbine so as to maintain its speed of rotation as constant. The variation in load

during the operation of a steam turbine can have a significant impact on its performance. In a practical situation the load frequently varies from the designed or economic load and thus there always exists a considerable deviation from the desired performance of the turbine.^[1] The primary objective in the steam turbine operation is to maintain a constant speed of rotation irrespective of the varying load. This can be achieved by means of governing in a steam turbine. There are many types of governors.

Throttle governing

Nozzle governing

By pass governing

Combination governing

Throttle governing – small turbines

Low initial cost and simple mechanism makes throttle governing the most apt method for small steam turbines. The mechanism is illustrated in figure 1. The valve is actuated by using a centrifugal governor which consists of flying balls attached to the arm of the sleeve. A geared mechanism connects the turbine shaft to the rotating shaft on which the sleeve reciprocates axially. With a reduction in the load the turbine shaft speed increases and brings about the movement of the flying balls away from the sleeve axis. This results in an axial movement of the sleeve followed by the activation of a lever, which in turn actuates the main stop valve to a partially opened position to control the flow rate.^[2]

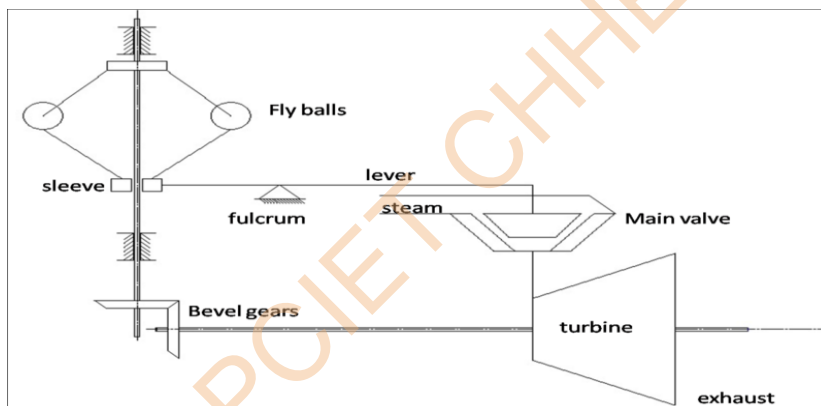

Throttle governing – big turbines

Where In larger steam turbines an oil operated servo mechanism is used in order to enhance the lever sensitivity. The use of a relay system magnifies the small deflections of the lever connected to the governor sleeve.^[2] The differential lever is connected at both the ends to the governor sleeve and the throttle valve spindle respectively. The pilot valves spindle is also connected to the same lever at some intermediate position. Both the pilot valves cover one port each in the oil chamber. The outlets of the oil chamber are connected to an oil drain tank through pipes. The decrease in load during operation of the turbine will bring about increase in the shaft speed thereby lifting the governor sleeve. Deflection occurs in the lever and due to this the pilot valve spindle raises up opening the upper port for oil entry and lower port for oil exit. Pressurized oil from the oil tank enters the cylinder and pushes the relay piston downwards. As the relay piston moves the throttle valve spindle attached to it also descends and partially closes the valve. Thus the steam flow rates can be controlled. When the load on the turbine increases the deflections in the lever

are such that the lower port is opened for oil entry and upper port for oil exit. The relay piston moves upwards and the throttle valve spindle ascends upwards opening the valve. The variation of the steam consumption rate \dot{m} (kg/h) with the turbine load during throttle governing is linear and is given by the “willan’s line”.^[1]

Nozzle governing

In nozzle governing the flow rate of steam is regulated by opening and shutting of sets of nozzles rather than regulating its pressure.^[3] In this method groups of two, three or more nozzles form a set and each set is controlled by a separate valve. The actuation of individual valve closes the corresponding set of nozzle thereby controlling the flow rate. In actual turbine, nozzle governing is applied only to the first stage whereas the subsequent stages remain unaffected.^[1] Since no regulation to the pressure is applied, the advantage of this method lies in the exploitation of full boiler pressure and temperature. Figure 2 shows the mechanism of nozzle governing applied to steam turbines.^[2] As shown in the figure the three sets of nozzles are controlled by means of three separate valves.

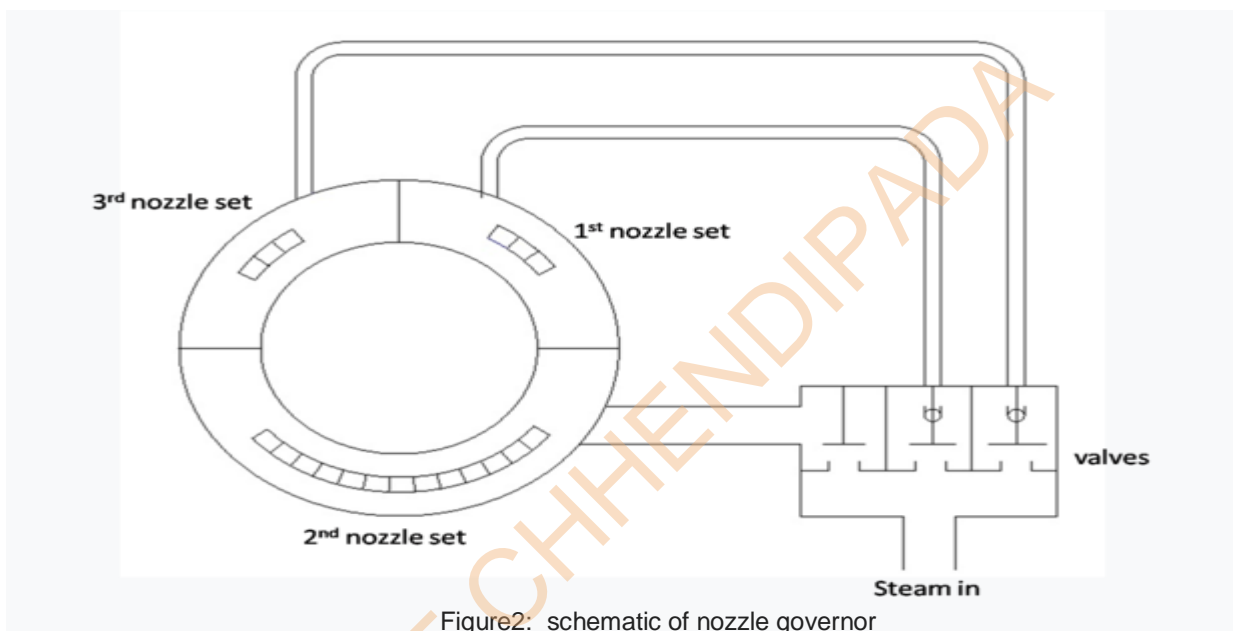
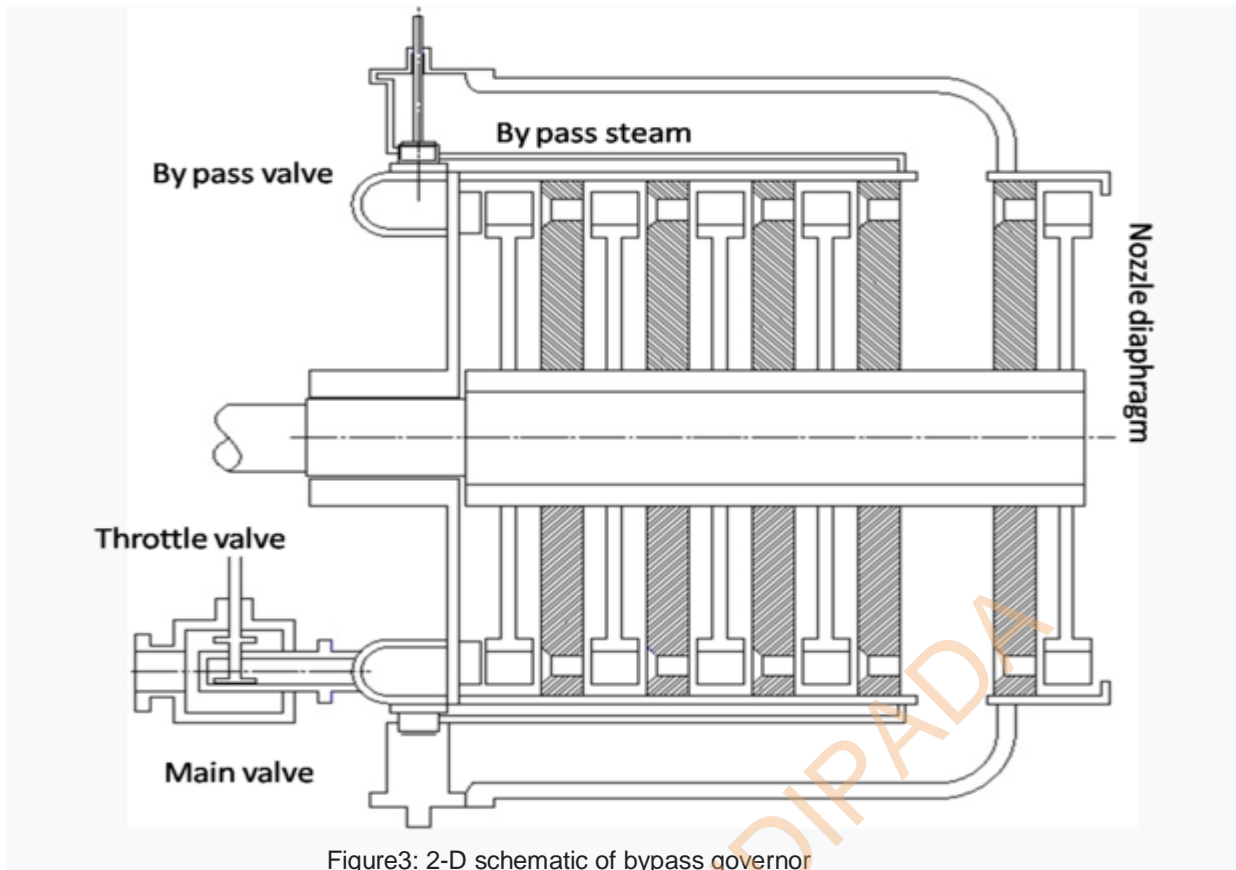

Figure2: schematic of nozzle governor

By pass governing

Occasionally the turbine is overloaded for short durations. During such operation, bypass valves are opened and fresh steam is introduced into the later stages of the turbine. This generates more energy to satisfy the increased load. The schematic of bypass governing is as shown in figure3.



Combination governing

Combination governing employs usage of any two of the above mentioned methods of governing. Generally bypass and nozzle governing are used simultaneously to match the load on turbine as shown in figure 3.

Q. What do you mean by Artificial Draught explain it ? 2016, 3(b)

Ans: The draught produced by any means other than by chimney is called artificial draught. An artificial draught produced by a fan or a blower is known as mechanical or fan draught and that produced by a steam jet is known as steam jet draught.

Mechanical draught:-

Draught produced by a fan or blower it may be three types

1. Induced Draught
2. Forced draught
3. Balanced Draught

INDUCED DRAUGHT:-

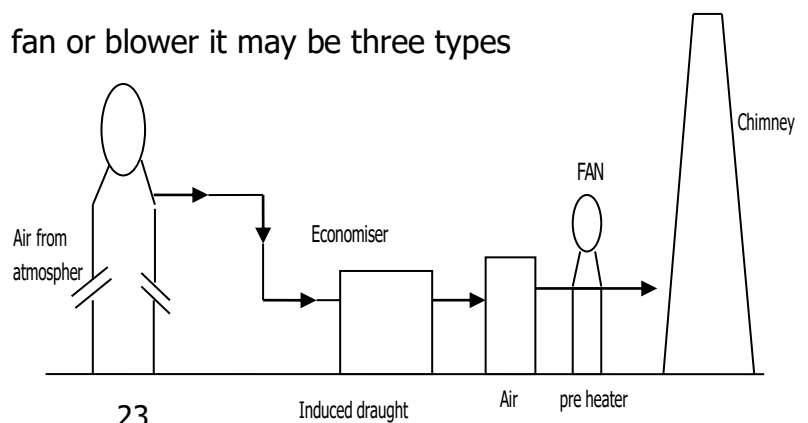

The fan is placed near the base of the chimney. The fan draws the flue gases from the furnace. So the pressure above the fuel bed is reduced below the atmospheric pressure. The fresh air rushes to the furnace and after combustion, the flue gases get discharged through the chimney in the atmosphere.

FORCED DRAUGHT:-

The fan is located near or at the base of the boiler grate to force atmospheric air on to the furnace under pressure.

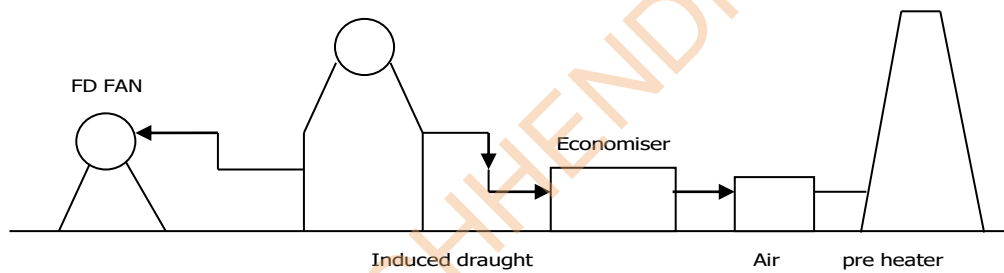

The pressure helps on circulation of flue gases through component of boiler and then through chimney to the atmosphere.

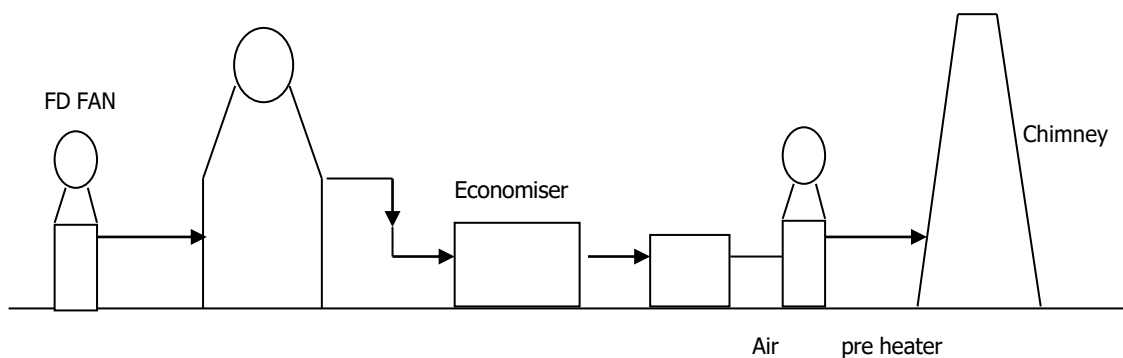

A forced draught fan located near the grate supplied, air under the pressure through the furnace and an induced draught fan located near the chimney base, drawn in flue gases through the economizer, air preheater etc. & discharges then into the atmosphere through a chimney.

Q. Advantages and Disadvantages of Artificial draught over natural draught(2012-s)

Ans:Advantages:-

- i. It is more economical.
- ii. It is better in control.
- iii. The flow of air through the grate and furnace is uniform.
- iv. It produced more draught.
- v. Its rate of combustion is very high.
- vi. Low grate fuel can be used.
- vii. The p_1 air flow can be regulated according to the changing requirement.
- viii. It is not affected by the atmospheric temp.
- ix. It reduced the amount of smoke.
- x. It reduces the height of chimney.
- xi. It increases the efficiency of the plant.
- xii. It reduces the fuel consumption.

Disadvantages:-

- i. Its initial cost is high.

	Forced Draught	post. d dr	Induced Draught
Q.	<ol style="list-style-type: none"> i. The fan is placed before the fire grate ii. The pressure inside the furnace is above the atmospheric pressure. iii. It forces fresh air in to combustion chamber. iv. It requires less power as the fan has to handle cold air only. v. The flow of air through grate and furnace is more uniform 		<ol style="list-style-type: none"> i. the fan is placed after the fire grate ii. The pressure inside the furnace is below the atmospheric pressure iii. It sucks hot gases from the combustion chamber and forces them in to the chimney. iv. It requires more power as the fan has to handle hot air and flue gases v. The flow of air through grate

Q. What is the function of an economizer and write down the advantages of its and also disadvantages, 2016, 4(a)

Ans: It is a device used to heat feed water by utilizing the heat in the exhaust, flue gases before leaving through the chimney. When the combustion gases leakage the boiler after giving most of their heat to water tubes, Super heaters tubes and reheats tubes they still passes lot of heat which of not recovered by means of some devices. Economizer is one of such heat recovering devices in which the temperatur5e of the fuel water is raised by means of out going flue gases before it is delivered to boiler drum. If an increase on feed water temperature by economizer is approximately 6°C then the boiler efficiency increases by 1 %.

- i. A well known type of economizer is greens economizer.
- ii. It is extensively used for stationary boiler.
- iii. It consists of large numbers of pipes or tubes placed in an enlargement of the flue gases between the boiler and chimney
- iv. These feed water flows through the tubes and the flue gases outside the tubes across them.
- v. These tubes are 2.75 meters long, 114 mm external diameter & 11.5 mm thick and are made of steel.

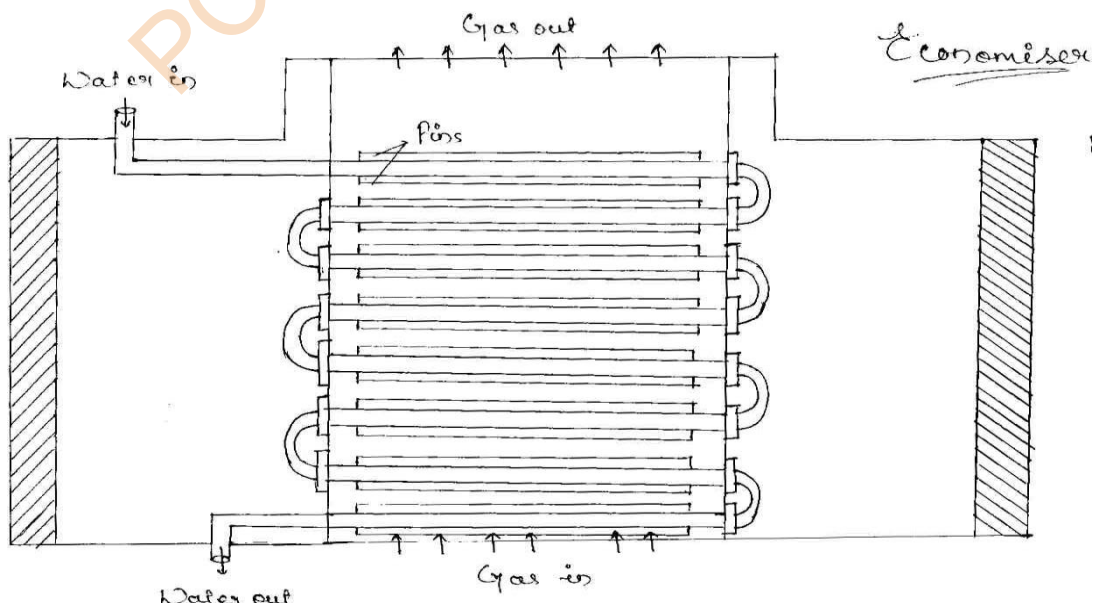

- vi. The flue gases move around the pipes in the direction opposite to the flow of water.
- vii. So the heat transfer through the surface of the pipe take place and water is there by heated.
- viii. A blow off cock is provided at the back of end pipes to remove sediments, scales etc.

Advantages:

- a. There is about 15 – 20 % coal saving
- b. It increasing the steam raising capacity of the boiler.
- c. It prevents the formation of scales, sediments etc.
- d. Increases the boiler efficiency.

Disadvantages:

- a. Cost of installation is sometimes high.
- b. Maintenance and regular cleaning is expensive.
- c. Extra floor space is occupied.

Q. Explain the function of superheater and write down the advantages of it ?(2016)

- Ans:**
- It is an important device of a steam generating unit.
 - Its purpose is to increase the temperature of saturated steam without raising its pressure.
 - It is very important accessories of a boiler and can be used both on fire tube & water tube boiler.
 - It is placed in the path of hot flue gases from the furnace.
 - The heat given up by these flue gases is used on super heating the steam.
 - The figure shows sudgen's superheater installed in a Lancashire boiler.
 - It consists of two steel headers to which are attached solid drawn 'U' tubes of steel.
 - These tubes are arranged in groups of four and one pair of the headers generally carries ten of these groups or total of forty tubes.
 - The steam from the boiler enters and leaves the headers as shown by the arrows.
 - It shows how the steam pipes may be arranged as to pass the steam through the superheater or direct to the main steam pipe.
 - When the steam is taken from the boiler direct to the main steam pipe, the valves v_1 and v_2 are closed and v_3 is opened.

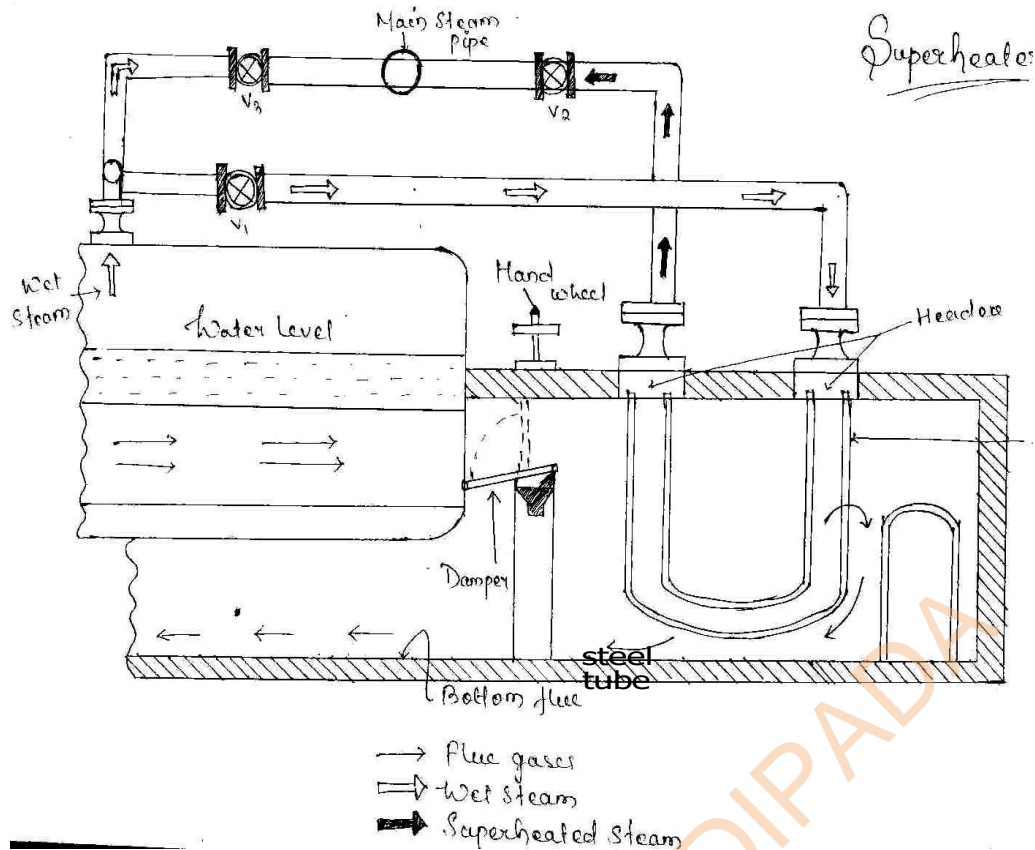

- When the steam is passed through the super heater v_3 is closed v_1 and v_2 is opened.
- The path of the gas is controlled by damper which is operated by the hand wheel.
- There are two types of super heaters
 - a. Convective super heater
 - b. Radical super heater

Advantages:

- a. Steam consumption of engine or turbine is reduced.
- b. Losses due to condensation in the cylinder and the steam pipes are reduced.
- c. Erosion of steam plant is increased.
- d. Efficiency of the steam plant is increased.

Function of condenser 2019

In systems involving heat transfer, a **condenser** is a device or unit used to condense a gaseous substance into a liquid state through cooling. ... **Condensers** are used in air conditioning,

industrial chemical processes such as distillation, steam power plants and other heat-exchange systems.

Q. What is the function of feed water heater ? 2014-s 2017-S

- Ans:**→ The function of the feed water heater is to raise the temperature of feed water by means of steam before the feed water is supplied to the boiler.
- The heat being taken from the exhaust steam of steam engine cylinders or steam turbines.
 - The feed water heater which is described is known as closed type feed water heater.
 - It is installed in between the feed pump and the boiler shell.
 - The closed type feed water heater consist of a cylindrical shell AB which is provided inside with two compartments C and D.
 - The feed water to be heated is pumped into the feed water heater through one set of pipe P_1 and inlet out of its through another set of pipes P_2 , both set of pipes being fitted to the compartment C and D.
 - Exhaust steam from the engine cylinder or steam turbines enters the feed water heater through an inlet pipe O_1 and is let out as. Enter condensate through an outlet pipe O_2 .
 - The steam while passing round the pipes P_1 and P_2 gives out its heat to the circulating water and thus condensed.

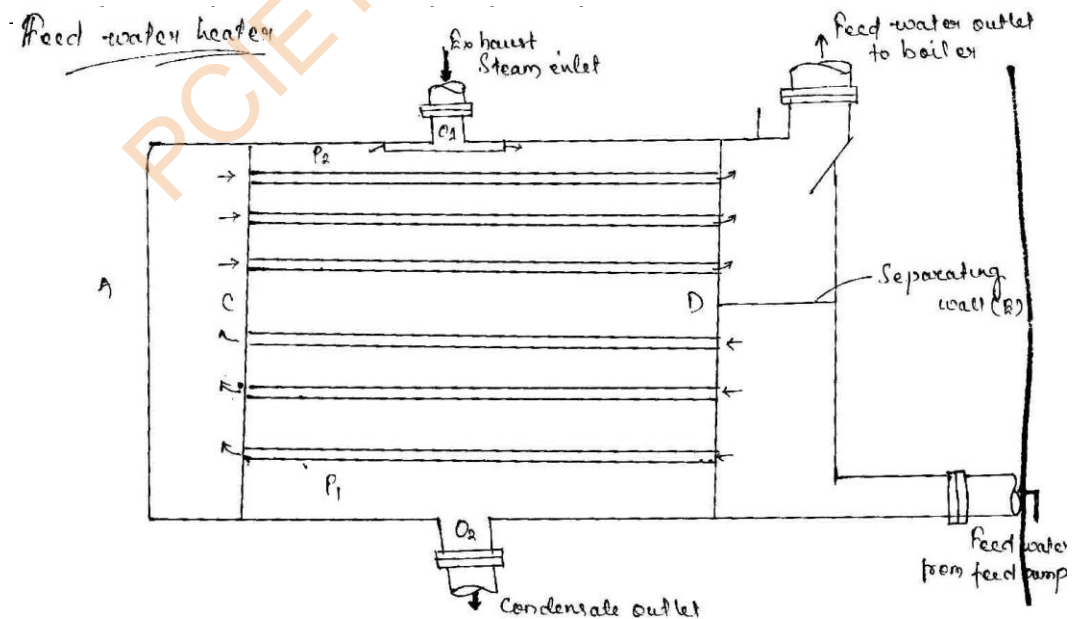

Q. Define thermal efficiency ? 2016 4(a)

Ans: It is the ratio of heat equivalent to one kilowatt hour to the total heat supplied to the steam per kwh.

$$\therefore \text{Thermal efficiency} = \frac{360 \times p}{ms(h_1 - hf_4)}$$

Where ms = mass of steam supplied in kg/h.

P = power developed in kw.

Efficiency ratio. It is also known as relative efficiency. It is defined as the ratio of thermal to rankine efficiency.

$$\therefore \text{efficiency Ratio} = \frac{\text{thermal efficiency}}{\text{Rankine efficiency}}$$

Q. Define work Ratio ? 2015 , 2017-S

Ans:It is defined as the ratio network output tot the gross output.

$$\begin{aligned} \therefore \text{Work Ratio} &= \frac{\text{Net work output}}{\text{Gross work output}} \\ &= \frac{\text{Turbine work} - \text{Comprssor work}}{\text{Turbine work}} \end{aligned}$$

Q REHEAT FACTOR 2017- S

In any multistage steam turbine with continuous expansion through the stages, the cumulative heat is the sum of the heat drops in the individual stages ; the **reheat factor** is the ratio of the cumulative heat to the adiabatic drop from initial condition to exhaust pressure.

Q. Define specific steam consumption ? 2015 , 2017-S

Ans:It is also known as steam rate or specific rate of flow of steam. It is defined as the mass of steam that must be supplied to a steam engine or turbine in order to develop a unit amount of work or power output. Mathematically specific steam consumption.

$$= \frac{1\text{kwh}}{W} = \frac{3600}{W}$$

Q. Cooling tower(2016)

Ans:In power plants the hot water from condenser is cooled in cooling tower, so that it can be reused in condenser for condensation of steam. In a cooling tower water is made of trickle down drop by drop so that it comes in contact with the air moving in the opposite direction. As a result of this some water is evaporated and is taken away from the bulk of water, which is thus cooled.

The cooling towers may also be classified as follows

- a. Natural draught cooling towers
- b. Mechanical draught cooling towers.

NATURAL DRAUGHT COOLING TOWERS 2017-S 2019

In this type of tower, the hot water from the condenser is pumped to the troughs and nozzles situated near the bottom. Through spray the water falls in the form of droplets into a pond situated at the bottom of the tower. The air enters the cooling tower from air openings provided near the base, rises upward and takes up the heat of falling water. A concrete hyperbolic cooling tower is shown in fig. This tower has the following advantages over mechanical towers.

- i. Low operating and maintenance cost.
- ii. It gives more or less trouble free operation.
- iii. Considerable less ground area required.
- iv. The enlarged top of the towers are listed below.

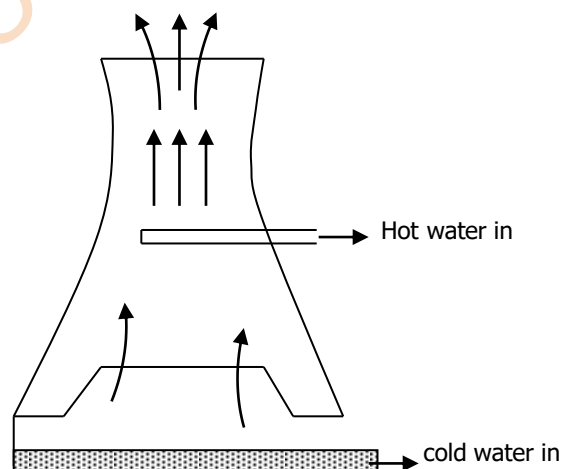

While initial cost may be higher, the saving in fan power, longer life and less maintenance always favor for his this type of tower. It is also more favorable over mechanical draught cooling towers as central station size increases.

MECHANICAL DRAUGHT COOKLING TOWERS

In these towers the draught of air the for cooling the tower is produced mechanically be means of propeller fans. These towers are usually built in cells or units, the capacity depending upon the number of cells used.

Q. Comparison of forced and induced draught towers(2016)

Ans: Forced Draught cooling towers

Advantages:

- a. more efficient (than induced draught)
- b. No problem of fan blade erosion (as it handles dry air only)
- c. more safe
- d. The vibration and noise are minimum

Disadvantages:

- a. The fan size is limited to 4 meters.
- b. Power requirement high (approximately for the same capacity)
- c. In the cold weather, ice is formed on nearby equipments and buildings or in the fan housing itself. The frost in the fan outlet can break the fan blades.

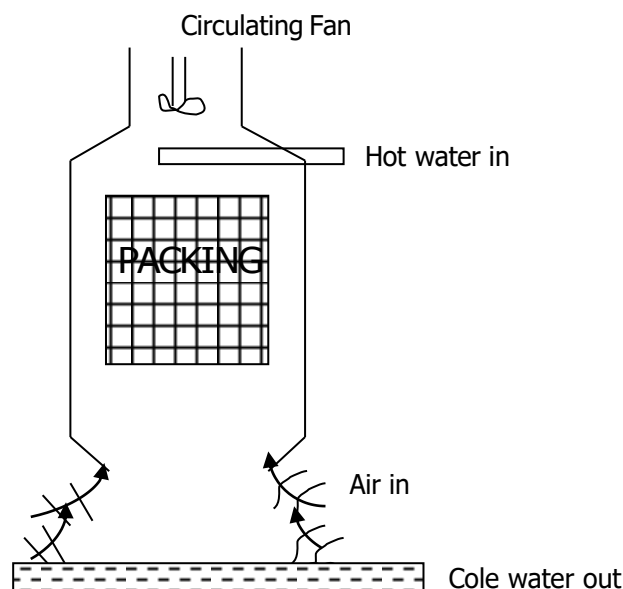

Fig. shows a forced draught cooling tower. It is similar to natural draught tower as far as interior construction is concerned, but the sides of the tower are closed and form an air and water tight structure, except for fan openings at the base for the inlet of fresh air and the outlet at the top for the exit of air and vapors. There are hoods at the base projecting from the main portion from the main portion of the tower where the fans are placed for forcing the air, into the tower.

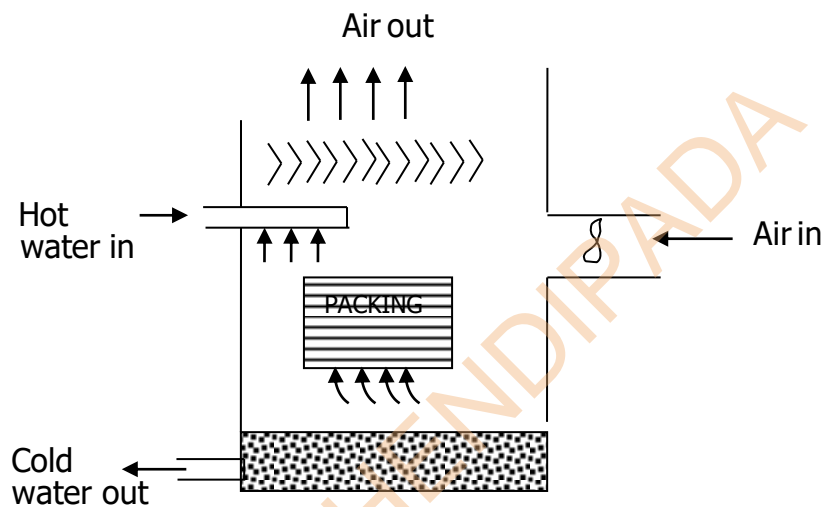

Fig. shows an induced draught cooling tower in these towers, the fans are placed at the top of the tower they draw the air in through louvers extending all around the tower at its base.

Q. Induced draught cooling towers.(2016)

Advantages:

- The coldest water come in contact with the driest air and warmest water come in contact with the most humid air
- In this tower, the recirculation is seldom a problem.
- Lower first cost (due to the reduced pump capacity and smaller length of water pipes)
- Less space required.
- This tower is capable of cooling through a wide range.

Disadvantages:

- The air velocities through the packing are unevenly distributed and it has very little movement near the walls and centre of tower.
- Higher H.P. motor is required to drive the fan comparatively. This is due to the fact that the static pressure loss is higher as restricted area at base tends to choke off the flow of higher velocity air.

Q -EXPLAIN THE REQUIREMENT OF GOOD CONDENSING SYSTEM 2017-S

the principle requirement of condensing plant is 1) condenser 2) condensate pump 3) hot well 4) boiler pump 5) air extraction pump 6) cooling tower 7) cooling water pump

- 1) CONDENSER:- it is closed vessel in which steam is condensed. the steam gives up heat energy to coolent the process of condensation
- 2) condensate pump :- it is pump which remove condensate from the condenser to the hot well.
- 3) Hot well:- it is a sump between condenser and boiler which receive condensate pumped by the condensate pump .
- 4) - air extra pump – it is a extraction pump which extract air from the condenser .
- 5) boiler feed pump :- it is a pump which pump the condensate from hotwell to boiler. it increases the pressure above boiler pressure.
- 6) cooling tower- it is a tower used for cooling the water which discharged from the condenser
- 7) cooling water pump – it is a pump which circulate the cooling water through the condenser.

Q- Advantages of using steam condenser in steam power plant 2017-s

The various advantages of a surface condenser are as follows:

1. The condensate can be used as boiler feed water.
2. Cooling water of even poor quality can be used because the cooling water does not come in direct contact with steam.
3. High vacuum (about 73.5 cm of Hg) can be obtained in the surface condenser. This increases the thermal efficiency of the plant.

CHAPTER:3

Q. Explain the effect of nuclear radiation and disposal of nuclear waste ?

2012(s)2017-S

Ans: Effect of Nuclear Radiation Biological Damage – Biological effects upon living tissues exposed to a radiation field result from the interaction of the radiation and the tissue. The interaction between radiation and tissue is manifested in three ways, ionization, displacement of atoms and absorption of neutrons by nuclei of tissue.

- i. Ionization: The formation of ion-pair in tissue require 32.5 eV or energy. About 3100 ion – pairs are formed when a single 1 MeV beta particle is stopped by tissue. If one cm² area of tissue surface is subjected to a beam of β -radiation of 1000 β -particles/cm²/sec, about 31×10^6 ion-pairs are formed each second. This absorption results in complete damage of tissues in the body of man or beast or bird α , β and γ - radiations all ionize tissue into which they penetrate.
- ii. Displacement : If the energy of the impinging particle is sufficiently high, an atoms in the tissue is displaced from its normal lattice position with possible adverse effects. Neutron and γ - radiation result in atomic displacement.
- iii. Absorption:- Absorption of neutron by a tissue nucleus results in forming a radioactive nucleus and change the chemical nature of the nucleus. This severe alteration of the tissue cause malfunctioning of the cell and cell damage may have severe biological effects including genetic modifications.

The inhalation of radioactive materials in air, water or food also presents a radiation hazard. Somebody elements are eliminated from the body rapidly, others becomes chemically involved in such a way as to give a serious long time problem strontium -90 has an affinity for bones and if it is absorbed by the bones through water, air or food, it will have a serious effect as bone marrow.

Disposal of nuclear waste:- Many radioactive isotopes have their own rate of decay. The weak isotopes are harmless, the intensely active soon disappear. To eliminate the latter, it is merely necessary to store the spend fuel under 6m deep water until they have cooled. The cooling period may be as long as 100 days. During the cooling period the intensely active and short-lived

isotopes and their radiations disappear , About half of the radioactive elements that remain after cooling offer no great difficulty in the processing.

Several kinds of radioactive wastes – gaseous, liquid and solid – are formed in the various phases of nuclear fuel cycle. These must be disposed off in such a manner that there is no hazard to human, animal or plant life. Solids of low and moderate activity are buried at depths of few meters at carefully selected sites. Gaseous wastes are discharged to the atmosphere through high stacks, liquid having low or intermediate levels of radioactivity are often given a preliminary treatment to remove most of the activity in form of solid precipitate and then discharged in dry wells or deep pits. Sometimes treated liquids are kept in hold-up tank before discharge for a period to allow part of the radioactive to decay.

The disposal of the radioactive wastes after recovery of uranium and plutonium from waste fuel possesses a real problem. The waste solution which is rich in fission products is concentrated by evaporation under vacuum and then stored in a stainless steel tank, enclosed in a concrete vault and buried under the earth (nearly 1 km below)

The radioactivity of the waste solution generates heat to cause trouble from corrosion or even boiling so that submerged tanks are provided with cooling coils to keep the temperature at 50°C.

Different methods for nuclear waste disposal. The nuclear waste from the reactor is classified as :

- i. High level waste
- ii. Medium level waste and
- iii. Low level waste

The high level waste has radioactivity above 1000 curie. The medium level waste radioactivity lies 100 to 1000 curie and low level waste radioactivity is below 100 curie.

The spent fuel is withdrawn from the reactor and placed in a water pond where heat is removed and shorter lived radio nuclides decay. The pond water is continually treated to remove activity due to release of fuel from defective cladding.

The spent fuel is then transferred to the reprocessing plant where cladding that contains the fuel is removed and the fuel is dissolved in nitric acid. The U^{235} (20 to 90%) and Pu^{239} are then removed leaving 99 % non-volatile fission products behind in solution known as "Highly Active liquid waste". The separated U^{235} and Pu^{239} are further purified and either stored for future use or fabricated in to fresh fuel for reactor.

The waste from the cooling pond (known as central storage) is then transferred to intermediate storage and kept there for a period of 30 to 100 years where most of the reaction heat and radioactivity nature is reduced to a considerably low level. Then the waste is permanently shifted in the final storage where it is permanently buried either in the earth or sea.

Q. The Chain Reaction 2015 5(b)

Ans: A chain reaction is that process in which the number of neutrons keeps on multiplying rapidly (in geometrical progression) during fission till whole of the fissionable material is disintegrated. The chain reaction will become self-sustaining or self propagating only if, for every neutron absorbed, at least one fission neutron becomes available for causing fission of another nucleus. This condition can be conveniently expressed in the form of multiplication factor or reproduction factor of the system which may be defined as

$$K = \frac{\text{No. of neutrons in any particular generation}}{\text{No. of neutrons in the preceding generation}}$$

If $K > 1$, chain reaction will continue and if $K < 1$ chain reaction cannot be maintained. Fig. shows schematically a chain reaction which when set off ultimately leads to a rapidly growing avalanche having the characteristic of an explosion. The rate of growth of the chain process is shown in fig.

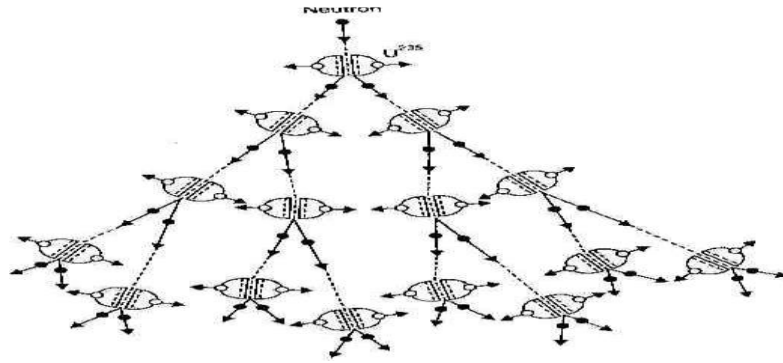

Q. Briefly explain the working of PWR and BWR power plant. 2012(w) 5(c)2019

Ans: Working of pressurized water Reactor (PWR)

The arrangement of PWR is shown in the fig. In its simplest form a pressurized water reactor is a light water cooled and moderated reactor. It uses enriched uranium as fuel. The principal parts of the reactor are :

1. Pressure vessel
2. Reactor thermal shield
3. Fuel elements
4. Control rods
5. Reactor containment
6. Reactor pressuriser

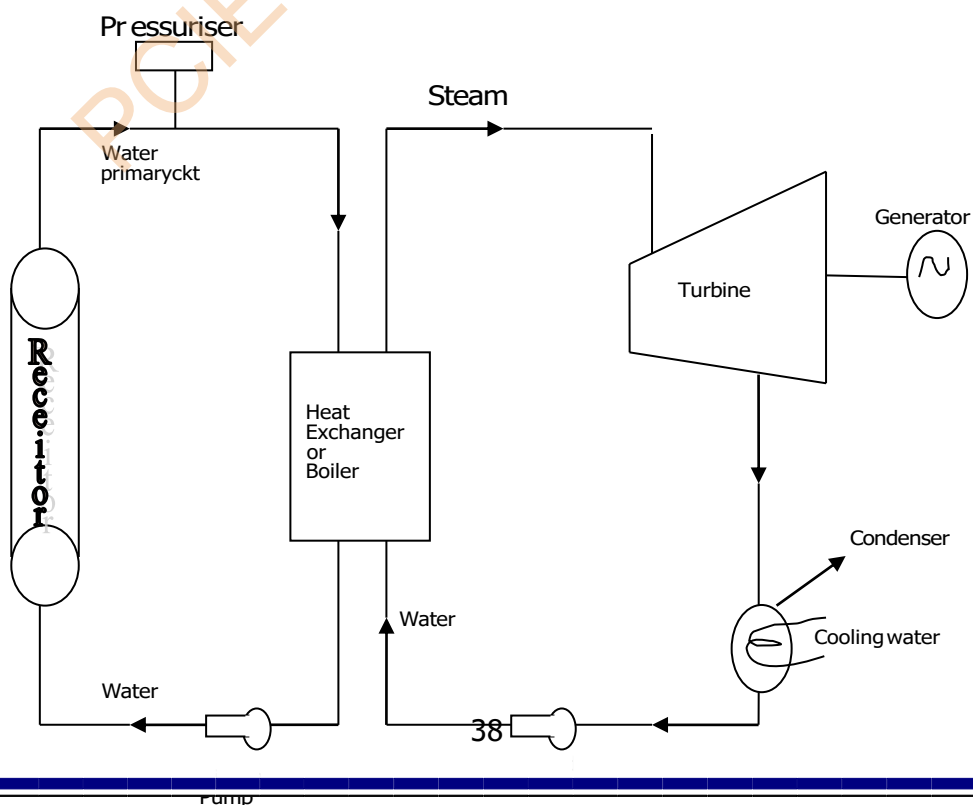

In PWR there are two circuits of water, one primary circuit which passes through the fuel core and is radioactive. This primary circuit then produces steam in a secondary circuit. Which consist of heat exchanger or boiler and the turbine. As such the steam in the turbine is not radioactive and need not be shielded. The pressure in the primary circuit should be high so that the boiling of water takes place at high pressure. A pressurizing tank keeps the water at about 100 kg F/cm². So that it will not boil. As more pressure rises and pressurizes the entire circuit. The pressure may be reduced by providing cooling coils or spraying water on the steam, water acts both as coolant as well as moderator. Either heavy water or light water may be used for the above purpose. This reactor can produce only saturated steam by providing a separate furnace the steam formed from the reactor could be super heated.

Advantages of PWR

1. Water used in reactor is cheap and easily available.
2. the reactor is compact and power density is high.
3. Fission products remain contained in the reactor and are not circulated.
4. A small number of control rods is required.
5. This reactor allows to reduce the fuel cost.

Disadvantages:

1. Capital cost is high as high primary circuit requires strong pressure vessel.
2. In the secondary circuit the thermodynamic efficiency of this plant is quite 1000.
3. Fuel suffers radiation damage and therefore processing is difficult.
4. Severe corrosion problems.
5. Low volume ratio of moderator to fuel makes fuel element design and insertion of control rods.
6. Fuel element fabrication is expensive.

Boiling Water Reactor (BWR) 2017 -S

In boiling water reactor enriched fuel is reached. As compare to PWR the arrangement of BWR plant is simple. The plant can be safely operated using natural convection within the core or forced circulation as shown in fig. for the safe operation of the reactor the pressure in the forced circulation must be maintained constant irrespective of the load. In case of part load operation of the turbine some steam is by passed.

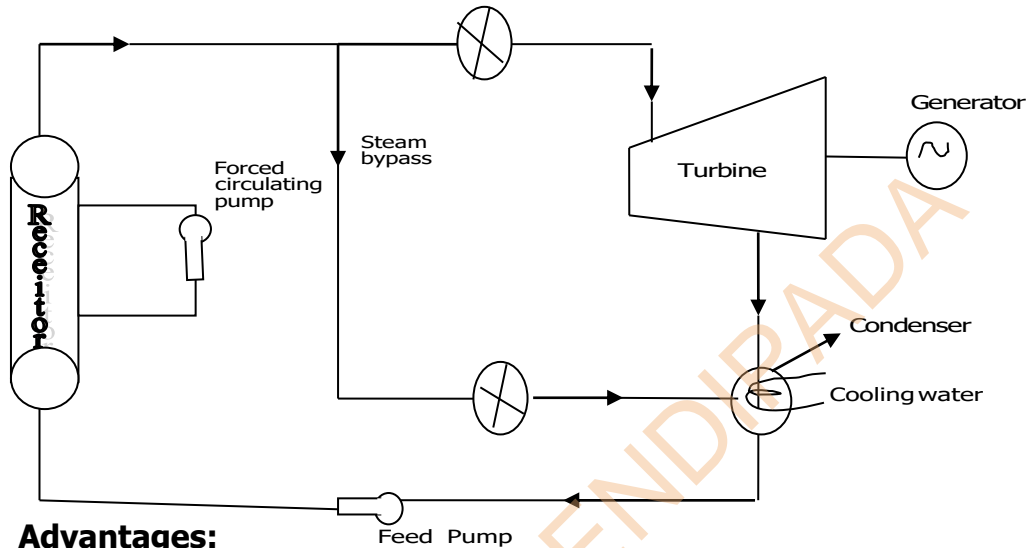

Advantages:

1. Heat exchanger circuit is eliminated and consequently there is gain in thermal efficiency and gain in cost.
2. there is use of a lower pressure vessel for the reactor which further reduces cost and simplifies contaminant problems.
3. The metal temperature remain low for given output conditions.
4. The cycle for BWR is more efficient then PWR.

Disadvantages:

1. Possibility of radioactive contamination in the turbine mechanism, should there be any failure of fuel element.
2. More elaborate safety precautions needed which are costly.
3. Wastage of steam resulting in lower thermal efficiency.
4. Boiling limits power density, only 3-5 % by mass can be converted to steam per pass through the boiler.

5. The possibility of burn out of fuel is more in this reactor than PWR as boiling of water on the surface of the fuel is allowed

Q. Difference between Fission & Fusion reaction

2015(s) 2(d)

Ans:

FISSION REACTION	FUSION REACTION
<ul style="list-style-type: none"> → It is the process that occurs when neutron collides with the nucleus of certain of the heavy atoms, causing the original nucleus to split into two or more unequal fragments. → About one thousand of the mass is converted into energy → Nuclear reaction residual problem is great → Amount of Radio active material in a Fission reactor is high → Because of higher radio active material health hazard is high. 	<ul style="list-style-type: none"> → It is the process of combining or fusing two lighter nuclear into a stable and heavier nuclide. → About four thousand of the mass is converted into energy. → Residual problem is much less. → Amount of radio active material in a fusion reactor is less. → Because of less radioactive material health hazard is less

Q. Advantage and Disadvantage of gas turbine plant over Diesel power plant.(2012-s)

Ans: Advantage over Diesel plants:

1. The work develop per kg of air is large compared with diesel plant.
2. Less vibration due to perfect balancing.
3. Less space requirement.
4. Capital cost considerably less.
5. Higher mechanical efficiency.
6. the running speed of the turbine (40,000 to 100, 000 rpm.) is considerably large compared to diesel engine (1000 – 2000 rpm)
7. Less installation and maintenance cost.
8. the torque characteristics of turbine plant are far better than diesel plants.
9. the ignition and lubrication systems are simpler
10. Poor quality fuels can be used.

Disadvantages:

1. Poor part load efficiency.
2. Special metals and alloys are required for different components of the plants.
3. Special cooling methods are required for cooling the turbine blades.
4. Short life.

Q. With neat sketch explain the function of different components of nuclear reactor 2013 (w) 5(b) , 2016 – 5(c)

Ans:the nuclear reactor may be regarded as a substitute for the boiler fire box of steam plant or combustion chamber of a gas turbine plant. The heat produced in the nuclear power plant is by fission where as in steam and gas turbine plants the heat is produced by combustion

The component of nuclear reactor are :-

1. Fuel
2. Moderator
3. Reflector
4. Coolant
5. Control rods
6. Shielding
7. Reactor vessel

Fuel:- The nuclear fuel which are U^{235} generally used in the reactor are ${}_{92}U^{235}$, ${}_{94}U^{235}$ among the three, the ${}_{92}U^{235}$ is naturally available upto 0.7 % in the uranium are the remaining is ${}_{92}U^{235}$. The fuel is shaped and located in the reactor in such a manner that the heat production within the reactor in such a manner that the heat production is uniform. The fuel and moderator are mixed to form a uniform mixture i.e. uranium and carbon and then it is used in the form of rods or plants in the reactor core. In heterogeneous reactor the fuel is used in the form of rods and plants and moderator surrounding the fuel

element. This arrangement commonly used in most of the reactor. The fuel rods are clad with aluminum stainless steel or prevent the oxidation of uranium.

Moderator: It is a material which reduces the kinetic energy of fast neutron to slow neutron. (13200 m/sec to 2200 m/sec) ,

→ the function of moderator is to increase the probability of reaction, light water, heavy water (D_2O), graphite are most common moderator used in reactor.

→ The desirable properties of a moderator in a reactor are

- i. High slowing down power
- ii. Low parasite capture
- iii. Non-Corrosiveness
- iv. Machinability
- v. High melting point
- vi. Chemical and radiation stability
- vii. High thermal conductivity

Reflector 2019 :-It is usually placed round the core to reflect back some of the neutrons that leak out from the surfaces of the core. It is generally made of the same material as the moderator.

Coolants:- The main purpose of the coolants in the reactor is to transfer the heat produced inside the reactor. The same heat carried by the coolants is used in the heat exchanger for further utilization in the power generation.

Properties:-

- i. Low parasite capture
- ii. Low melting point
- iii. High boiling point
- iv. Chemical and radiation stability
- v. Low viscosity
- vi. Non toxicity

- vii. Non corrosiveness
- viii. High specific heat
- ix. High density

Control rods:- the function of control rods are

- i. To start the nuclear chain reaction when the reactor is started from cold.
- ii. The chain reaction should be maintained at steady state condition.
- iii. To shut down the reactor automatically under emergency condition.
- iv. The material used for control rods must have very high absorption capacity for neutrons. The common material used for control rods are cadmium, boron etc.

Shielding : It is necessary in order to

- i. Protect the walls of the reactor vessel from radiation damage.
- ii. Protect operating personal from exposure to radiation.

Reactor Vessel:-

It encloses the reactor core, reactor and shield. It also provides the entrance and exit passages for directing has to withstand the pressure as high as 200 kg/cm^2 or above. The reactor core is generally placed at the bottom of the vessel.

**Q. Advantages of Nuclear Power Plants and a thermal power plant.
2016, 5(b)2019**

Ans: Some of the major advantages of nuclear power plants are :

- 1. A nuclear power plant needs less space as compared to other conventional power plant of equal size.
- 2. Nuclear power plants are well suited to meet large power demands. They give better performance at high load factors (80 to 90 %).

3. Since the fuel consumption is very small as compared to conventional type of power plants, therefore, there is saving in cost of the fuel transportation.
4. The nuclear power plants, besides producing large amount of power, produce valuable fissionable material which is produced when the fuel is renewed.
5. The operation of a nuclear power plant is more reliable.
6. Nuclear power plants are not affected by adverse weather conditions.
7. Bigger capacity of a nuclear power plant is an additional advantage.
8. The expenditure on metal structures piping, storage mechanisms is much lower for a nuclear power plant than a coal burning power plant.

Disadvantages/Limitations:

1. The capital cost of a nuclear power station is always high.
2. The danger of radioactivity always persists in the nuclear stations (inspite of utmost precautions and care).
3. These plants cannot be operated at varying load efficiently
4. The maintenance cost is always high (due to lack of standardization and high salaries of the trained personnel in this field of specialization).
5. The disposal of fission products is a big problem.
6. Working conditions in nuclear power station are always detrimental to the health of the workers.

CHAPTER:4

Q. Explain briefly different systems of diesel power plant with suitable diagram.(2012)2017-S

Ans: Different system of diesel power plant are :

1. **Fuel Supply System:-**

It is consist of fuel tank for the storage of fuel. Fuel filters and pump to transfer and inject the fuel. The fuel oil may be supplied at the plant site by trucks, rail, road, tank, cars etc

2. **Air intake and exhaust system:-**

It consist of pipes for the supply of air and exhaust of the gases. Filter are provided to remove dust etc from the incoming air. In the exhaust system silencer is provided to reduce the noise.

Filters may be of dry type (made up of cloth, fest, glass, wool etc) or oil bath type. 2nd oil bath type of filters the air is wept over or through a bath of oil in order that the particles of dust get coated. The duties of the air intake system are as follows.

- i. To clean the air intake supply.
- ii. To silence the intake air
- iii. To supply air for super charging

the intake system must cause a minimum pressure loss to avoid reducing engine capacity and raising the specific fuel consumption. Filters must be cleaned periodically to prevent pressure loss from clogging.

Q. Fuel System.(2017-S)

Ans: The fuel oil may be delivered at the plant site by trucks, railroad tank cars or barge and tankers. From tank car or truck the delivery is through the unloading facility to main storage tanks and then by transfer pumps to small service storage tanks known as engine day tanks. Large storage capacity allows purchasing fuel when prices are low. The main flow is made workable and practical by arranging the piping equipment with the necessary heaters, by passes, shut-offs, drain lines relief valves, strainers and filters, flow meters and temperature indicators. The actual flow plans depend on type of fuel, engine equipment, size of the plant etc. The tanks should contain manholes for internal access and repair, fill lines to receive oil, vent lines to discharge vapours, overflow return lines for controlling oil flow and a suction line to withdraw oil. Coils heated by hot water or steam reduce oil viscosity to lower pumping power needs.

The minimum storage capacity of at least a month's requirement of oil should be kept in bulk, but where advantage of seasonal fluctuations in cost of oil is to be availed, it may be necessary to provide storage for a few month's requirements. Day tanks supply the daily fuel need of engines and may contain a minimum of about 8 hours of oil requirement of the engines. These tanks are usually placed high so that oil may flow to engines under gravity.

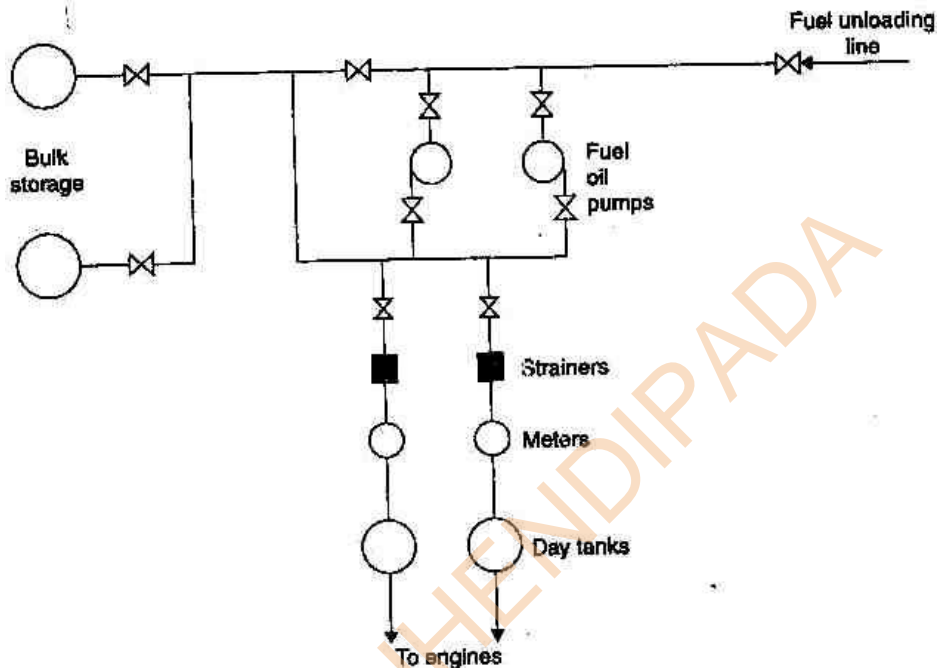

For satisfactory operation of a fuel oil supply system the following points should be taken care of :

1. there should be provisions for cleanliness and for changing over of lines during emergencies.
2. In all suction lines the pipe joints should be made tight.
3. Before being covered, all oil lines should be put under air pressure and the joints tested with soap solution. Small air leaks into the line can be the source of exasperating operating difficulties and are hard to remedy once the plant is in operation.
4. The piping between filter and the engine should be thoroughly oil flushed before being first placed in service.

5. Considerable importance should be given for cleanliness in handling bulk fuel oil. Dirt particles will ruin the fine lap of injection pumps or plug the injection nozzle orifices. So high-grade filters are of paramount importance to the diesel oil supply system.

Q. Fuel Injection System 2016(s)2017-S

The mechanical heart of the diesel engine is the fuel injection system. The engine can perform no better than its fuel injection system. A very small quantity of fuel must be measured out, injected, atomized, and mixed with combustion air. The mixing problem becomes more difficult the larger the cylinder and faster the rotative speed. Fortunately the high speed engines are the small bore automotive types ; however, special combustion arrangements such as pre combustion chambers, air cells, etc, are necessary to secure good mixing. Engines driving electrical generators have lower speeds and simple combustion chambers.

Functions of a fuel injection System:

1. Filter the fuel
2. Meter or measure the correct –quantity of fuel to be injected.
3. Time the fuel injection.
4. Control the rate of fuel injection.
5. Atomize or break up the fuel to fine particles.
6. Properly distribute the fuel in the combustion chamber.

The injection systems are manufactured with great accuracy, especially the parts that actually meter and inject the fuel. Some of the tolerances between the moving parts are very small of the order of one micron. Such closely fitting parts require special attention during manufacture and hence the injection systems are costly.

Types of fuel Injection Systems:

The following fuel injection systems are commonly used in diesel power station:

1. Common-rail injection system
2. Individual pump injection system
3. Distributor

Atomization of fuel oil has been secured by (i) air blast and (ii) pressure spray. Early diesel engines used air fuel injection at about 70 bar. This is sufficient not only to inject the oil, but also to atomize it for a rapid and thorough combustion. The expense of providing in air compressor and tank led to the development of "solid" injection, using a liquid pressure of between 100 and 200 bar which is sufficiently high to atomize the oil it forces through spray nozzles. Great advances have been made in the field of solid injection of the fuel through research and progress in fuel pump, spray nozzles and combustion chamber design.

1. COMMON RAIL INJECTION SYSTEM

Two types of common-rail injection system are shown in fig.4.11 and 4.12 respectively. Refer fig. 4.11, A single pump supplies high pressure fuel to header, a relief valve holds pressure constant. The control wedge adjusts the lift of mechanical operated valve to set amount and time of injection

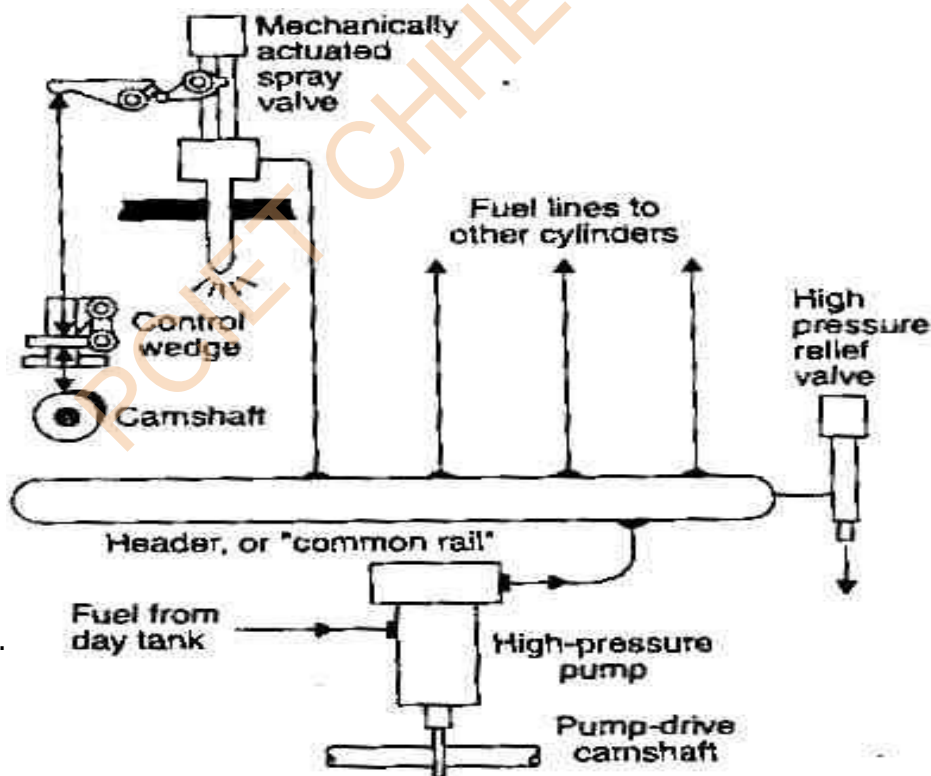

Refer Fig. relief and check.

ure. Pressure s merely as a

2. INI

Fig. 4.11

Refer fig. 4.13 , In this system an individual pump or pump cylinder connects directly to each fuel nozzle. Pump meters charge and control injection timing. Nozzles contain a delivery valve actuated by the fuel-oil pressure.

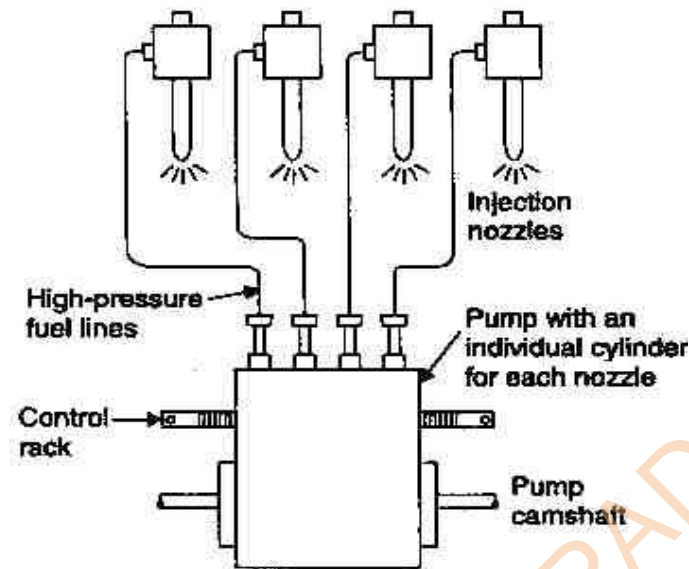

Fig. 4.13. Individual pump injection system.

Silencers must be used on some by stems to reduce high velocity air noises.

3. COOLING SYSTEM:

This system provides a proper amount of water circulation all around the engine to keep the temperature at reasonable level. Pumps are used to discharge the water inside and the hot water leaving the jacket is cooled in cooling pond or other devise and is re circulated again.

4. LUBRIATING SYSTEM:-

Lubrication is essential to reduce friction and wear of the rubbing part. It includes lubricating oil tank, pumps, filters and lubricating oil cooler.

5. STARTING SYSTEM:-

For the initial starting of engine the various devices used are compressed air, battery electric motor or self starter. The auxiliary equipment of diesel engine power plant.

Q. Cooling System(2016)

- i. It is know that whole of energy input to the engine is not converted to useful power and a major portion of this is wasted as heat in the outgoing exhaust gases and in heating the engine which if not removed would over

heat the engine which may damage the piston, piston rings, head and the cylinder liners.

- ii. This heat is dissipated by circulating water through the cylinder jacket and exhaust manifold jacket. Some heat is taken away by lubricating oil cooling.
- iii. The water should always enter the jackets from the bottom and leave at the top to ensure that it is always full of water.

There are mainly two methods of cooling I.C. Engine.

1. Air Cooling
2. Cooling.

AIR COOLING:

- i. In this method the heat is carried away by the air flowing over and around the engine cylinder.
- ii. It is used in scooters , motor, cycles etc.
- iii. Hence fins are cast on the cylinder head and cylinder barrel provide additional conductive and radiating surface.
- iv. The fins are arranged in such a way that they are at right angles to the cylinder axis.

Advantages:-

- a. The design of the engine becomes simpler and no water jackets are required.
- b. The cylinder can be of identical dimension and individually detachable and therefore cheaper to renew in case of accident etc.
- c. Absence of cooling pipe, radiator etc makes the cooling system simpler.
- d. No danger of coolant leakage etc.
- e. The engine is not subjected to freezing troubles.
- f. The weight per B.P. of the air cooled engine is less than that of water cooled engine.
- g. Installation easier.

Disadvantages:-

1. Their movement is noisy
2. Non-uniform cooling.
3. The output of air cooled is less than water cooled.
4. Maintenance is not easy.
5. Smaller useful compression ratio.

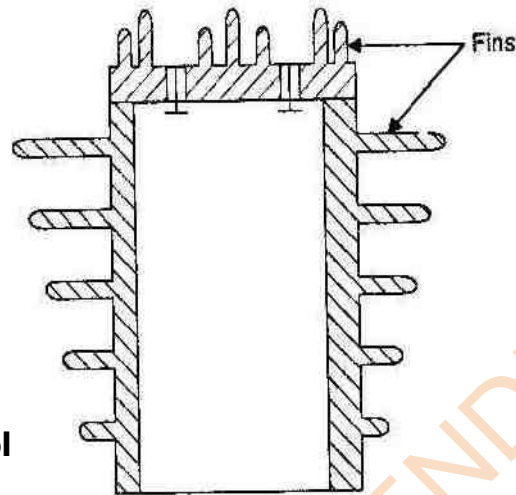

Fig. 4.17. Air cooling.

2. Liquid Cool

- i. In this cylinder walls and heads are provided with jackets through which the cooling liquid can circulate.
- ii. The heat is transferred from cylinder walls to the liquid by convection and conduction.
- iii. The liquid becomes heated in its passage through the jackets and is itself cooled by means of an air-cooled radiator system.
- iv. The heat from liquid in turn is transferred to air.

Various methods are used for circulating the water around the cylinder and cylinder head. These are :

1. Thermo siphon cooling
2. Forced or pump cooling
3. Cooling with thermostatic regulator
4. Pressurized water cooling
5. Evaporative cooling.

Thermo siphon Cooling

- i. The basis of this type of cooling is the fact that the water becomes lighter on heating.
- ii. The top of radiator is connected to the top of water jacket by a pipe and bottom of top of water jacket by a pipe and bottom of the radiator to the bottom of water jackets.
- iii. Water travels down the radiator across which air is passed to cool it.
- iv. the air flow can be provided for the purpose.
- v. The system has the advantage that it is quite simple and automatic and is without any water pump unless there is leak, there is nothing to get out of order.

The disadvantage of this system is that :

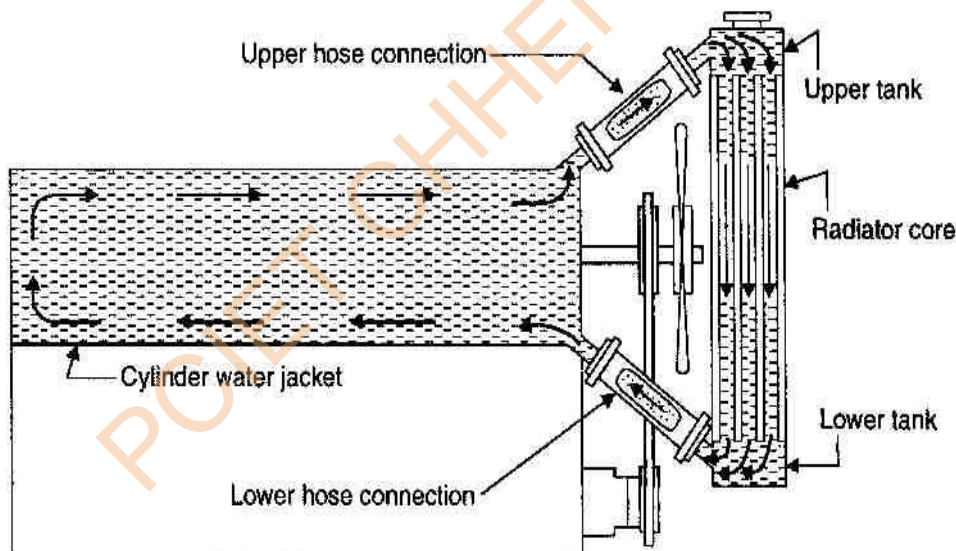

Fig. 4.18. Thermo-siphon cooling.

- Cooling depends only on the temperature and is independent of the engine speed.
- The rate of circulation is slow and insufficient.
- the circulation of water starts only after the engine has become hot enough to cause thermo siphon action.

- This system requires that the radiator be above the engine for gravity of water to engine.
- It is not widely used as present.

Advantages of liquid cooling over Air Cooling.

1. Compact design of engine with appreciable smaller frictional area is possible.
2. The fuel consumption of a high compression liquid cooled engine is rather lower than for air cooled one.
3. In case of water cooled engine installation is not necessary at the front of mobile vehicles aircrafts etc, as the cooling system can be conveniently located wherever required.
4. The size of the engine does not involve serious problem, as far as design of cooling system is concerned.

Disadvantages:

1. This is dependent system in which supply of water or liquid for circulation in the jacket is required.
2. Power absorbed by the pump for water circulation is considerably higher than that for cooling fans.
3. In the event of failure of cooling system serious damage may be caused to the engine.
4. Cost of the system is considerably high.
5. System requires considerable attention for the maintenance of various part of the system.

Lubrication System:- (2014)

The role played by the lubrication system in diesel power plant is more important than any other plant because of very high pressure and small clearance in these engines. The life of the engine, the overall efficiency of the plant and possible continuous service of the plant are dependent on the effectiveness of the purpose of the lubrication are:

1. To reduce friction and wear between the parts having relative motion.
2. To cool the surface by carrying away heat generated due to friction.
3. To seal a space adjoining the surface such as piston rings and cylinder liners.
4. To clean the surface by carrying away the carbon and metal particles caused by wear.
5. To absorb shock between bearing and other parts and consequently reduce noise.

The main parts of an engine which need lubrication are main crank shaft bearing, big end bearings, small end bearings, piston rings & cylinder walls, Valve mechanism, valve guides, valve tappets and rocker arms.

Various Lubrication system:-

1. Wet sump lubrication system
2. Dry sump lubrication system.
3. Mist lubrication system.

Wet sump lubrication system:-

This system employs a large capacity oil sump at the base of crank chamber, from which the oil is drawn by a low pressure oil pump and delivered to various parts. Oil then gradually returns back to the sump after serving the purpose, It consists of 3 methods.

1. Splash system
2. Semi pressure system.
3. Full pressure system.

Splash System:-

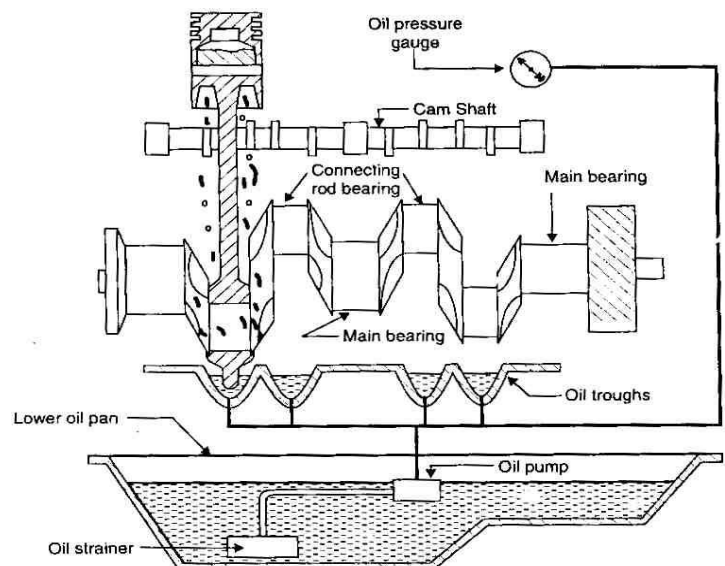

Fig. 4.23. Splash system.

- i. This system is used on some small four stroke.
- ii. In this case the caps on the big bearing of connecting rods is in the lowest positions just dip into oil through & thus direct the oil through holes in the caps to the big end bearing.
- iii. Due to splash of oil it reaches the lower portion of the cylinder walls, Crank shafts and other parts requiring lubrication.
- iv. Surplus oil flows back to the oil sump oil level in the through is maintained

WHY INLET MANIFOLD AND EXHAUST MANIFOLD ARE USED 2019

, an **exhaust manifold** collects the **exhaust** gases from multiple cylinders into a smaller number of pipes – often down to one pipe. The primary function of the **intake manifold** is to evenly distribute the combustion mixture (or just air in a direct injection engine) to each **intake** port in the cylinder head(s)

Q-ADVANTAGES AND DIS ADVANTAGES OF DIESEL POWER PLANT OVER STEAM POWER PLANT?2017-S

Advantages:

The advantages of diesel power plants are listed below:

1. Diesel power plant design is simple for installation.
2. The layout of the diesel power plant is quite simple.
3. The limited quantity of cooling water required.
4. Standby losses are very less as compared to other Power plants.
5. Low fuel cost for operation.
6. Smaller storage is needed for the fuel.
7. There is no problem of ash handling.
8. Less time monitoring is sufficient required.
9. For small capacity power generation, diesel power plant is more efficient than the steam power plant.
10. Quickly started and put on load.
11. They can respond to varying loads without having any difficulty.

Disadvantages:

The disadvantages of diesel power plants are listed below:

1. High Maintenance and operating cost.
2. The plant cost per kW power is comparatively more.
3. The working life of diesel power plant is small due to high maintenance.
4. The plant produces too much noise.
5. Diesel power plants are tough to construct for large scale.

EXPLAIN DETAILS ABOUT THE EXHAUST SYSTEM²⁰¹⁹

An **exhaust system** is usually **pipng** used to guide reaction **exhaust gases** away from a controlled **combustion** inside an **engine** or **stove**. The entire system conveys burnt gases from the engine and includes one or more **exhaust pipes**. Depending on the overall system design, the exhaust gas may flow through one or more of:

- **Cylinder head and exhaust manifold**
- A **turbocharger** to increase engine power.
- A **catalytic converter** to reduce **air pollution**.
- A **muffler** (North America) / **silencer** (UK/India), to reduce **noise**.

An exhaust pipe must be carefully designed to carry toxic and/or noxious gases away from the users of the machine. Indoor **generators** and **furnaces** can quickly fill an enclosed space with poisonous exhaust gases such as **hydrocarbons**, **carbon monoxide** and **nitrogen oxides**, if they are not properly vented to the outdoors. Also, the gases from most types of machines are very hot; the pipe must be heat-resistant, and it must not pass through or near anything that can

4-Stroke Cycle Engine	2-Stroke Cycle Engine
<p>i. There is one working stroke for every two revolutions of the crank shaft</p> <p>ii. Power developed is one half that of 2-stroke cycle engine for the reason stated in item no.1 above.</p> <p>iii. It is mostly a multi-cylinder engine.</p> <p>iv. Fluctuation of speed during a cycle is high. Hence a fly-wheel of heavier mass is necessary on the crank shaft of a stationary engine.</p> <p>v. Engine is heavy.</p> <p>vi. Engine design is complicated.</p> <p>vii. There is a separate exhaust port for exhaust of the burnt gas</p> <p>viii. There is no chance of wastage of useful gas through the exhaust port.</p>	<p>i. There is one working stroke for each revolution of the crank shaft.</p> <p>ii. Power developed is twice that of 4-stroke cycle engine for the reason stated in item no.1 above</p> <p>iii. It is mostly a single cylinder engine.</p> <p>iv. Fluctuation of speed during a cycle is less. Hence a fly-wheel of lighter mass is necessary on the crank shaft of stationary engine.</p> <p>v. Engine is light.</p> <p>vi. Engine design is simple.</p> <p>vii. There is no one single exhaust port like 4-stroke cycle engine.</p> <p>viii. There is a chance of wastage of the useful gas through the</p>

CHAPTER:5

What is hydel power plant ? 2012 (s) 7(a)

Q. What do you mean by run off river plant ? 2013(w) 7(a)

Ans: Pondage usually refers to the collection of water behind a dam of the plant and increases the steam capacity for a short period. The pondage capacity is decided to take the fluctuating load based on 24 hours basis storage plants may work. Satisfactory or base load and load. This type of plant as compared to that without pondage is more reliable of its generating capacity is less dependent on the flow rates of water available.

Q. Explain the important factor consider in the site selection of hydel power plant ? 2012(s) 7(b)

- Ans:**
1. Availability of water
 2. Water Storage
 3. Water head
 4. Distance from load centre
 5. Type of the load of site.

Availability of water:-

The design and capacity of the hydro plant greatly depend on the amount of water available of the site. The run off data along with precipitation of the prepared site with maximum and minimum quantity of water available in a year should be made available to

- a. Decide the capacity of the plant.

- b. Set up the beak load plant such as steam, diesel or as turbine plant.
- c. Provide adequate spill ways or gate relief during period.

Water Storage:- Since there is a wide variation in rainfall during the year, therefore it is always necessary to store the water for continues generation of powder maximum storage should the expenditure of the project.

The two types of storage in use are :

- a. the storage is so conducted that it can make water available for power generation of one year only in this case storage become scull in the beginning to the year and becomes empty of the end of each year.
- b. the storage is so counteracted that water is available in sufficient quantity even during the dry period.

Water Head:-

In order to generate the desired quantity of poser It is necessary that a large quantity of water at a sufficient head should be available. An increase in effective head for a given output reduce and the quantity of water required to be supplied to the turbine ?

Distance from Load Centre:-

If the site is close to the load centre the cold of transmission will be reduced.

Type of the load of the site.

The land of the site should be cheep and rocky. The dam constructed of the site should have large catchment area to store water at high head.

The necessary requirement of the foundation rocks for a necessary dom are as follows.

1. The rock should be effecting enough to withstand the stresses transmitted from the dam structure of well of the thrust of the water when the reservoir is full.
2. The rock should remain stable under all condition.

Q. Classification of Hydro-Electric Power Plants 2015, 7(b)

Ans: Hydro – electric power stations may be classified as follows

A. According to availability of head.

1. High head power plants
2. Medium head power plants
3. Low head power plants

B. According to the nature of load

1. Base load plants
2. Peak load plants

C. Accordingly to the quantity of water available

1. Run-of-river plant without pondage
2. Run-of-river plant with pondage
3. Storage type plants
4. Pump storage plants
5. Mini and micro-hydel plants

Q. Advantages and disadvantages of hydroelectric plants: (2016)2019

Ans: Advantages:-

1. No fuel charges.
2. It is highly reliable.
3. Maintenance and operation charges are very low.
4. Running cost of the plant is low.
5. Plant efficiency does not change with age.
6. It takes a few minutes to run and synchronize plant.
7. Less supervising staff is required.
8. No fuel transportation problem.
9. No ash problem as atmosphere is not polluted.

10. These plants are also used for flood control or irrigation.
22. The machines used in plants are more robust and generally runs at low speeds at 300 to 400 r.p.m.

Disadvantages:-

1. Initial cost of the plant is very high
2. It takes considerable long time for the erection of such plants.
3. such plants are usually located in hilly areas far away from the load centre.
4. Power generation by the hydro-electric plant is only dependent on the quantity of water available which in turn depends upon the natural phenol

RUN OFF RIVER PLANT 2019

Run-of-river hydroelectricity (ROR) or **run-of-the-river** hydroelectricity is a type of hydroelectric generation **plant** whereby little or no water storage is provided. ... Conventional hydro uses reservoirs, which regulate water for flood control and dispatchable electrical power.

HIGH HEAD STORAGE PLANT 2019

High Head Plants

- The water from the reservoir can be taken to a smaller storage known as a forebay, by means of tunnels.
- From the forebay, the water is then distributed to the penstocks.
- The function of the forebay is to distribute the water to penstocks leading to turbines.
- The inflow to the forebay is so regulated that the level in the forebay remains nearly constant.

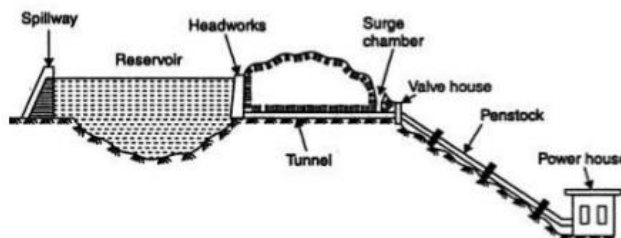

Fig. 5.2. High head power plant layout. The main dam, spillway, and powerhouse stand at widely separated locations. Water flows from the reservoir through a tunnel and penstocks to the turbines.

70